

햄스터 로봇으로 배우는 소프트웨어 교육

광운대학교 로봇학부
박광현

햄스터 로봇 소개

크기 · 무게 · 전원 스위치

3

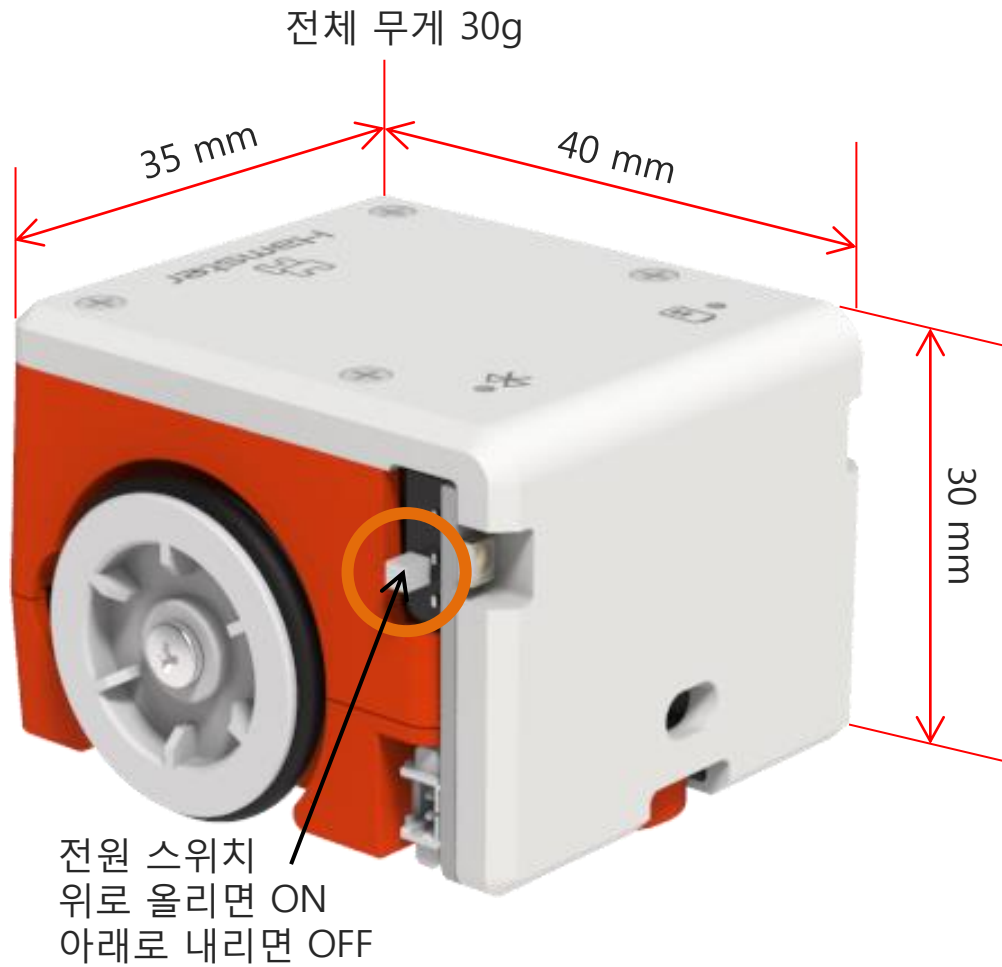

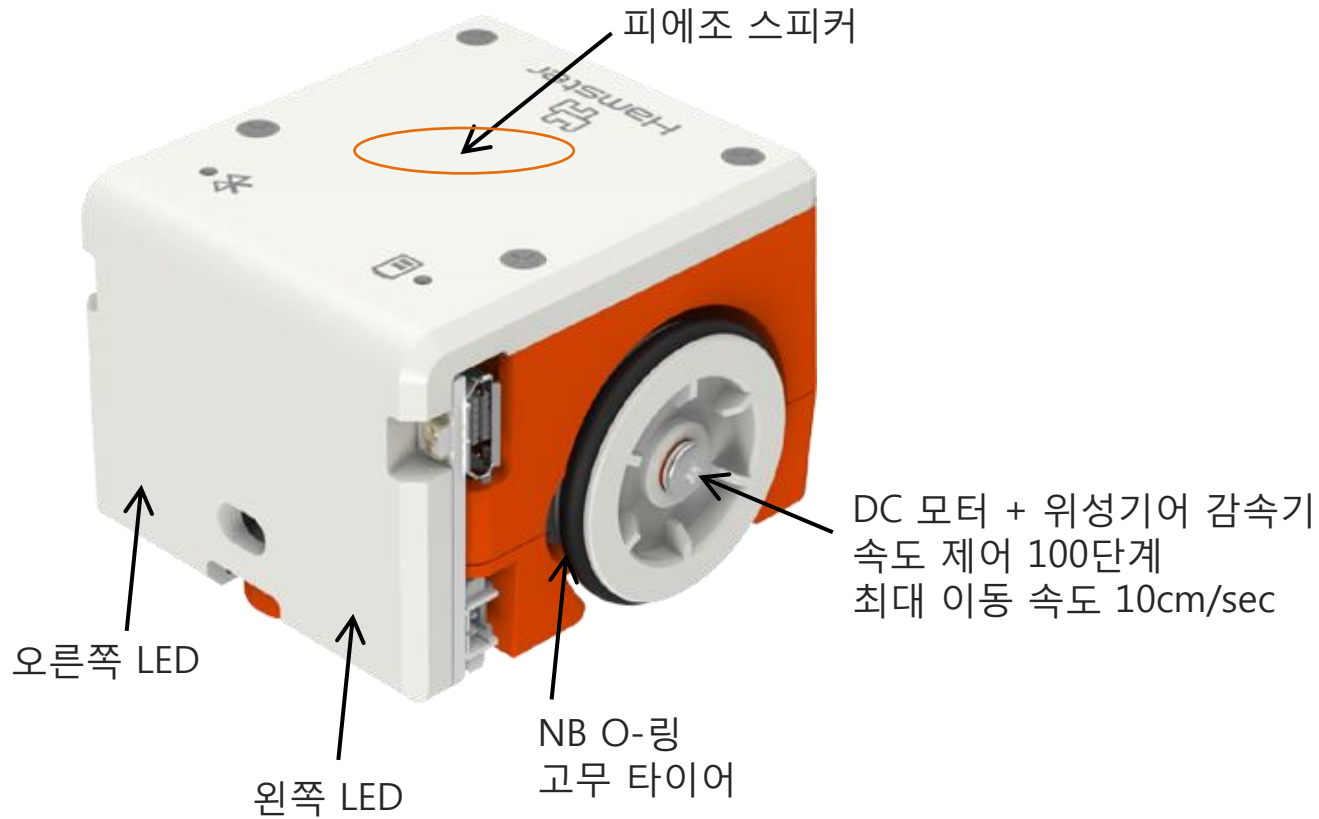

입력 장치

근접 센서 (적외선 센서)
1~30cm, 1mm 정밀도
햇빛 아래 동작 가능



왼쪽 바닥 센서
(적외선 센서)
0~255단계 감지





내장 리튬 배터리 3.7V, 120mA
충전 약 30분
연속 동작 평균 1시간
대기 최대 12시간



보조 전원 단자
3.7V 리튬 폴리머 전지



외부 입출력 단자 (포트A, 포트B)
디지털 입력, ADC 입력
디지털 출력, 아날로그(PWM) 출력
아날로그 서보 제어 출력



엔트리 실행 및 햄스터 로봇 연결

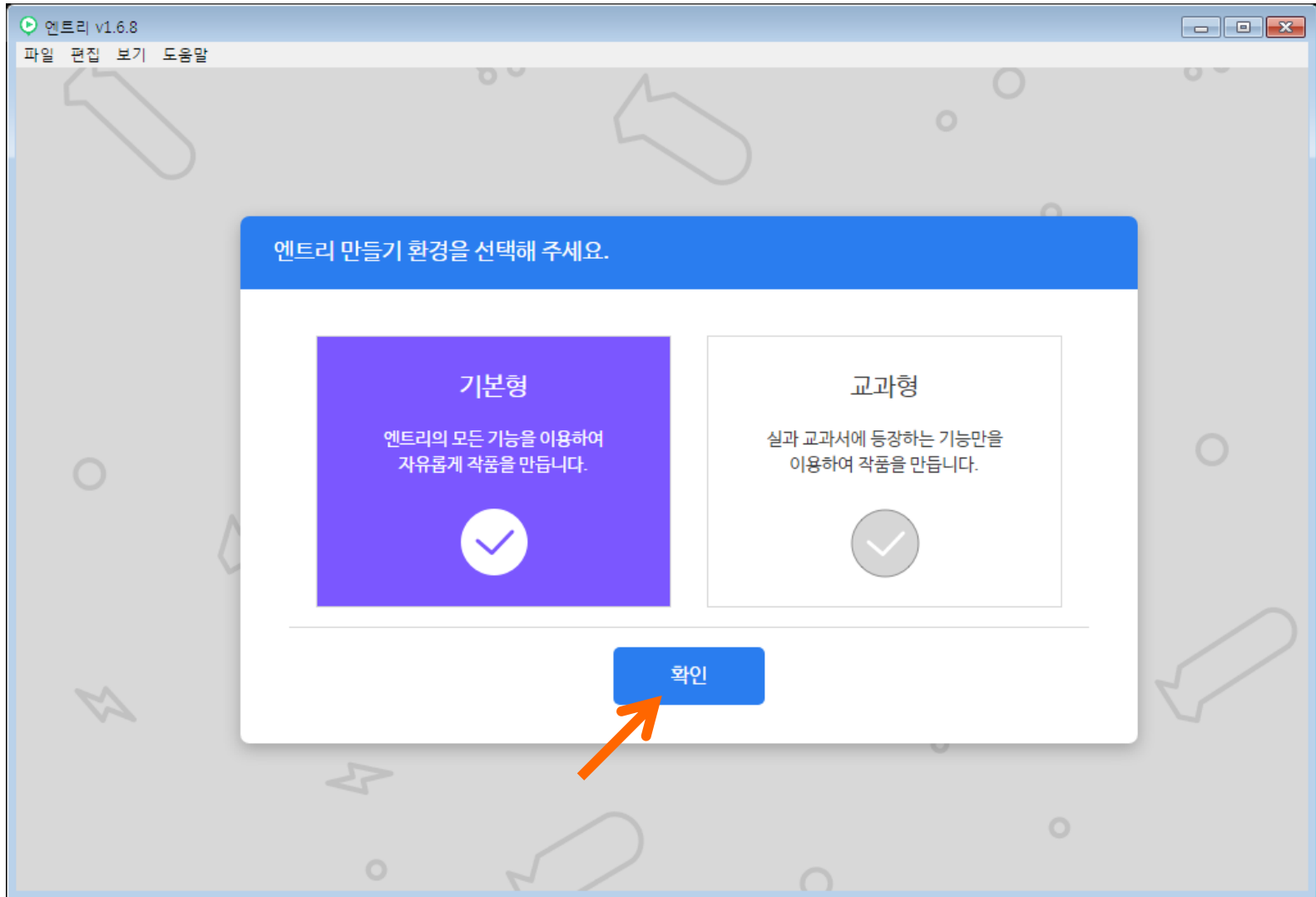

- 제일 아래의 하드웨어 탭 클릭

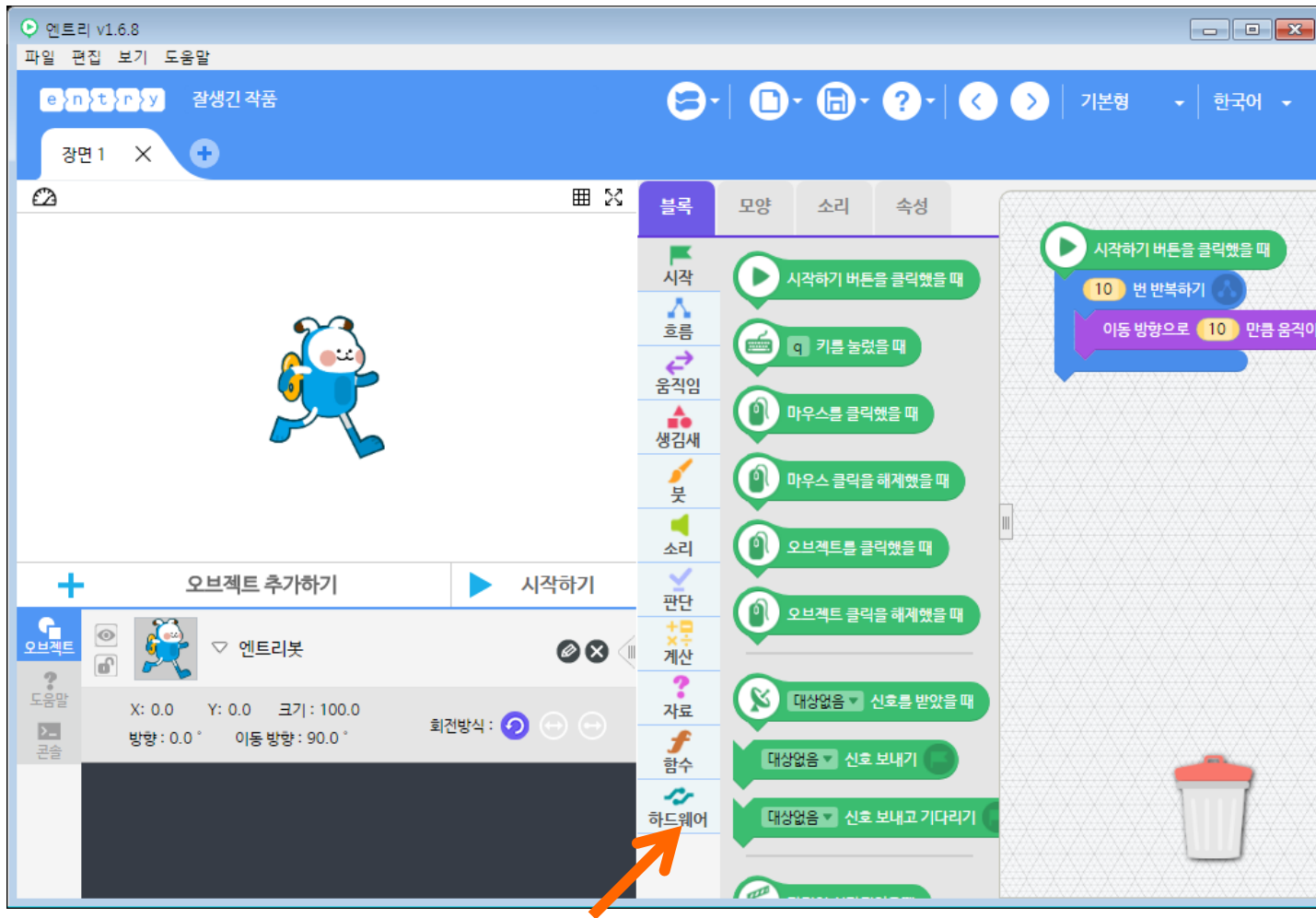

- 연결 프로그램 열기 클릭

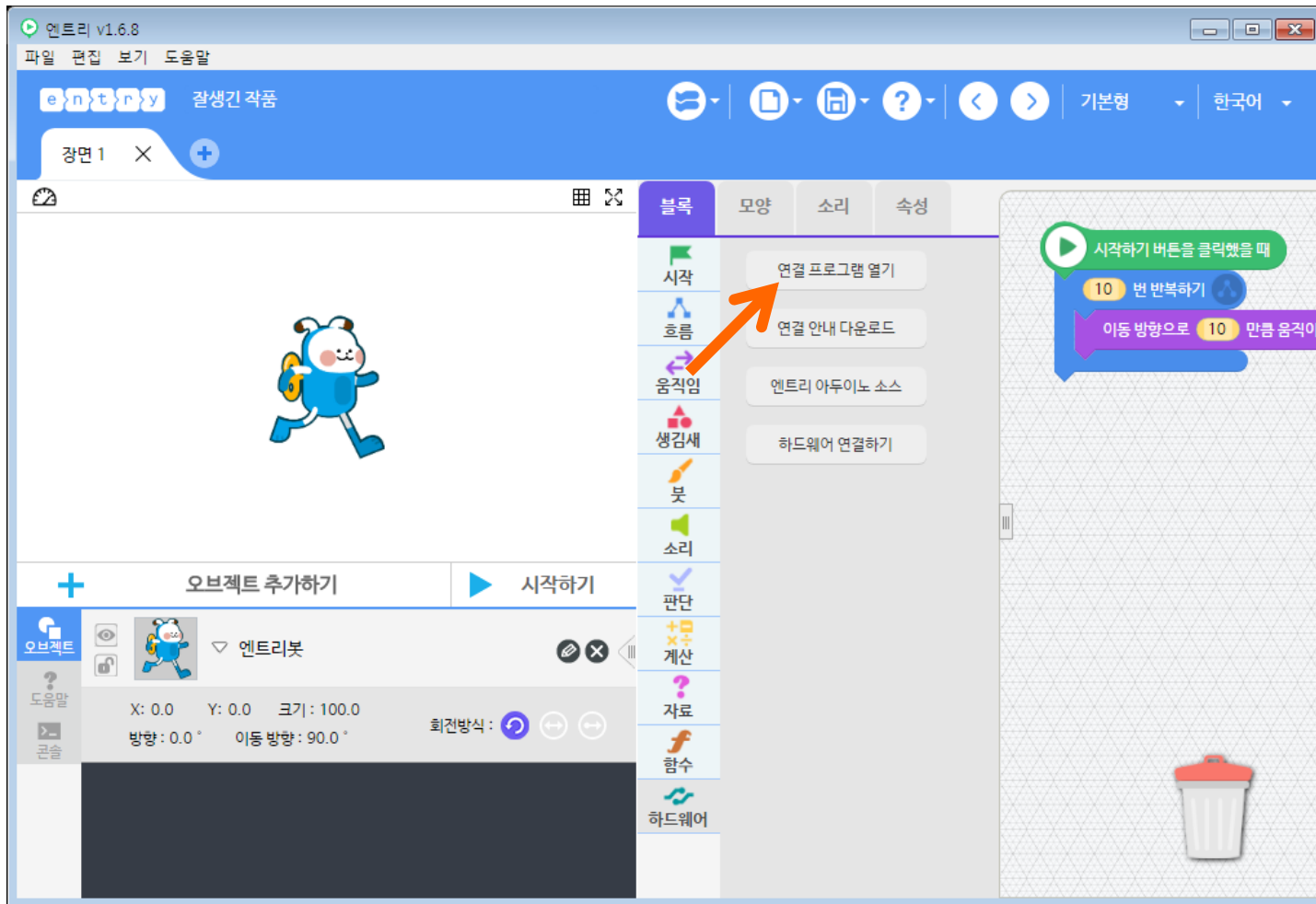

- 아래로 스크롤하여 햄스터 클릭



- USB 동글을 PC의 USB 단자에 연결



- 햄스터 로봇의 전원을 켜고
USB 동글 가까이 가져 감 (15cm 이내)
- 뽁 소리가 나면 연결된 것임



- 연결 성공으로 바뀌고
- 에디터에 햄스터 로봇용 블록이 나타남

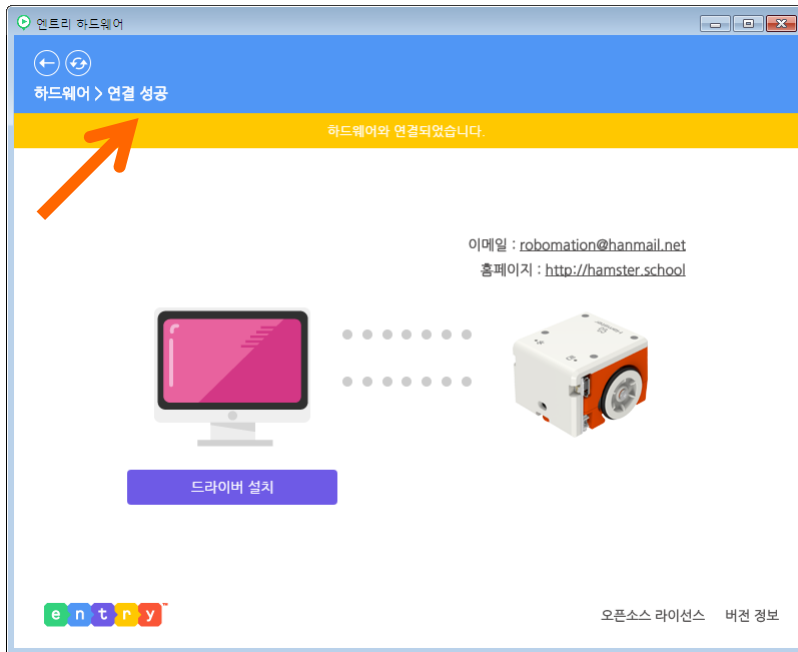

이동하기

왼쪽 바퀴 30 오른쪽 바퀴 30 (으)로 정하기



▶ 시작하기 버튼을 클릭했을 때

왼쪽 바퀴 30 오른쪽 바퀴 30 (으)로 정하기



오른쪽 바퀴 왼쪽 바퀴



▶ 시작하기 버튼을 클릭했을 때

왼쪽 바퀴 **-30** 오른쪽 바퀴 **-30** (으)로 정하기



오른쪽 바퀴 왼쪽 바퀴



▶ 시작하기 버튼을 클릭했을 때

왼쪽 바퀴 **-30** 오른쪽 바퀴 **30** (으)로 정하기



▶ 시작하기 버튼을 클릭했을 때

왼쪽 바퀴 0 오른쪽 바퀴 30 (으)로 정하기



▶ 시작하기 버튼을 클릭했을 때

왼쪽 바퀴 20 오른쪽 바퀴 40 (으)로 정하기



왼쪽 바퀴 30 오른쪽 바퀴 30 (으)로 정하기

2 초 기다리기

- A4 용지에 사각형과 원을 그립니다.
- 햄스터 로봇이 장애물(사각형)을 피해 목적지(원) 안에 들어가도록 합니다.

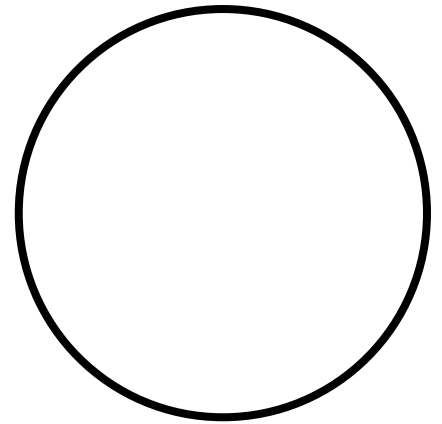
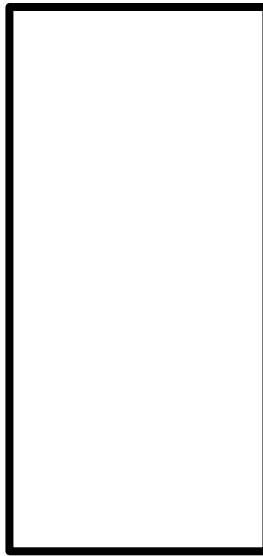

근접 센서 사용하기

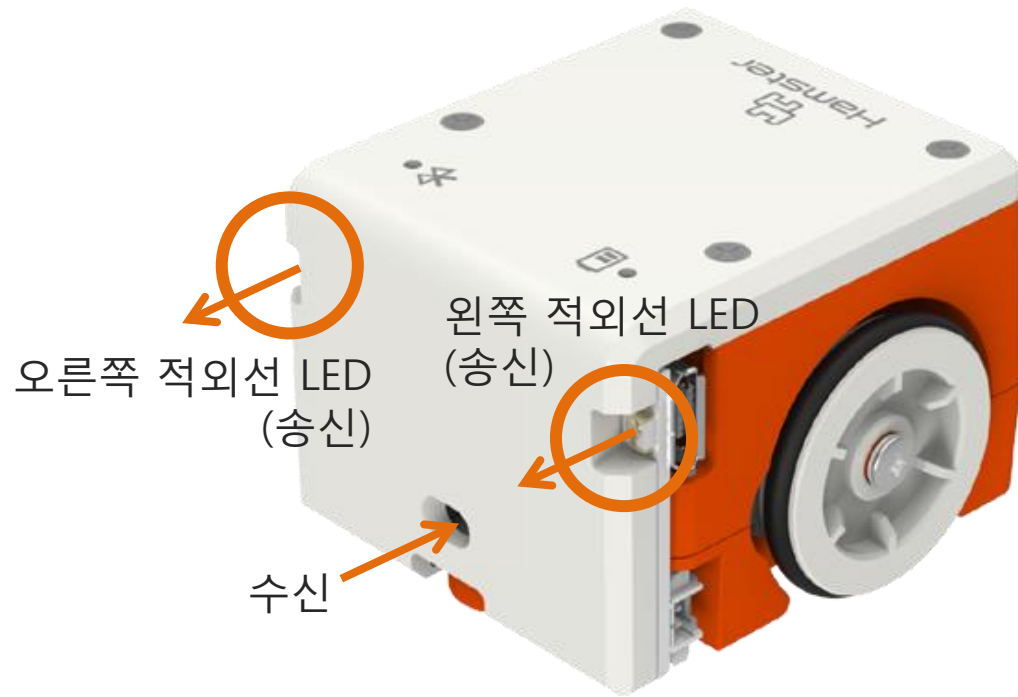

- 어느 거리 이상 손과 가까워지면 뒤로 물러납니다.
- 어느 거리 이상 손과 멀어지면 앞으로 다가옵니다.

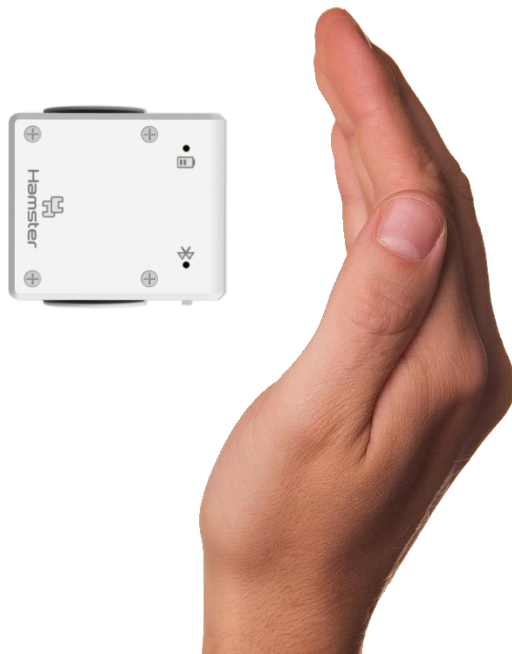

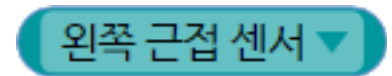
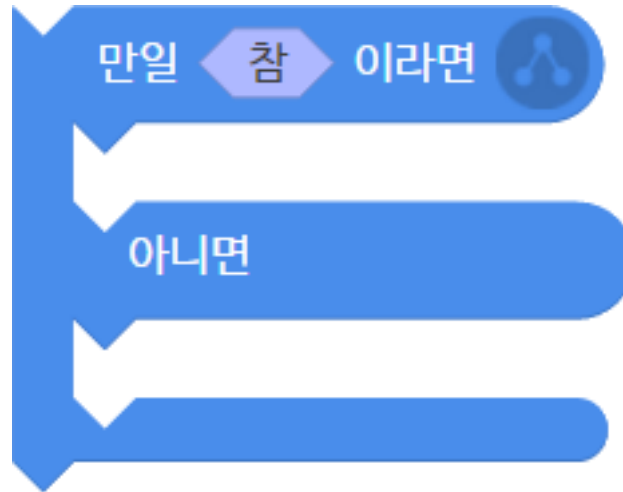
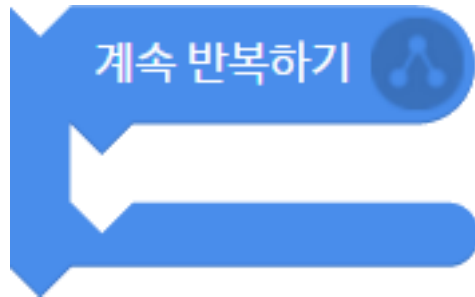

- 흐름 탭 클릭

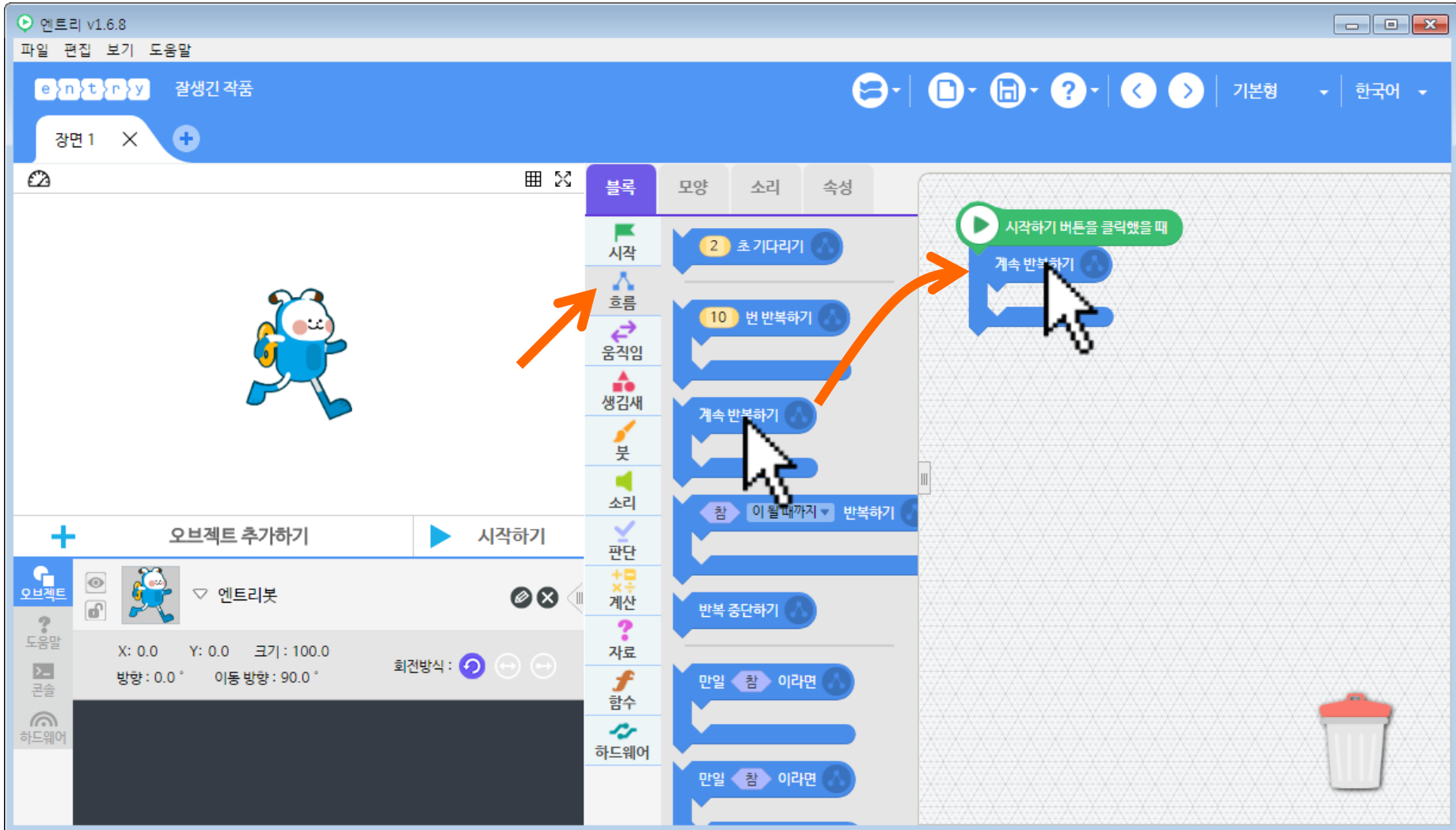

- 흐름 탭 클릭

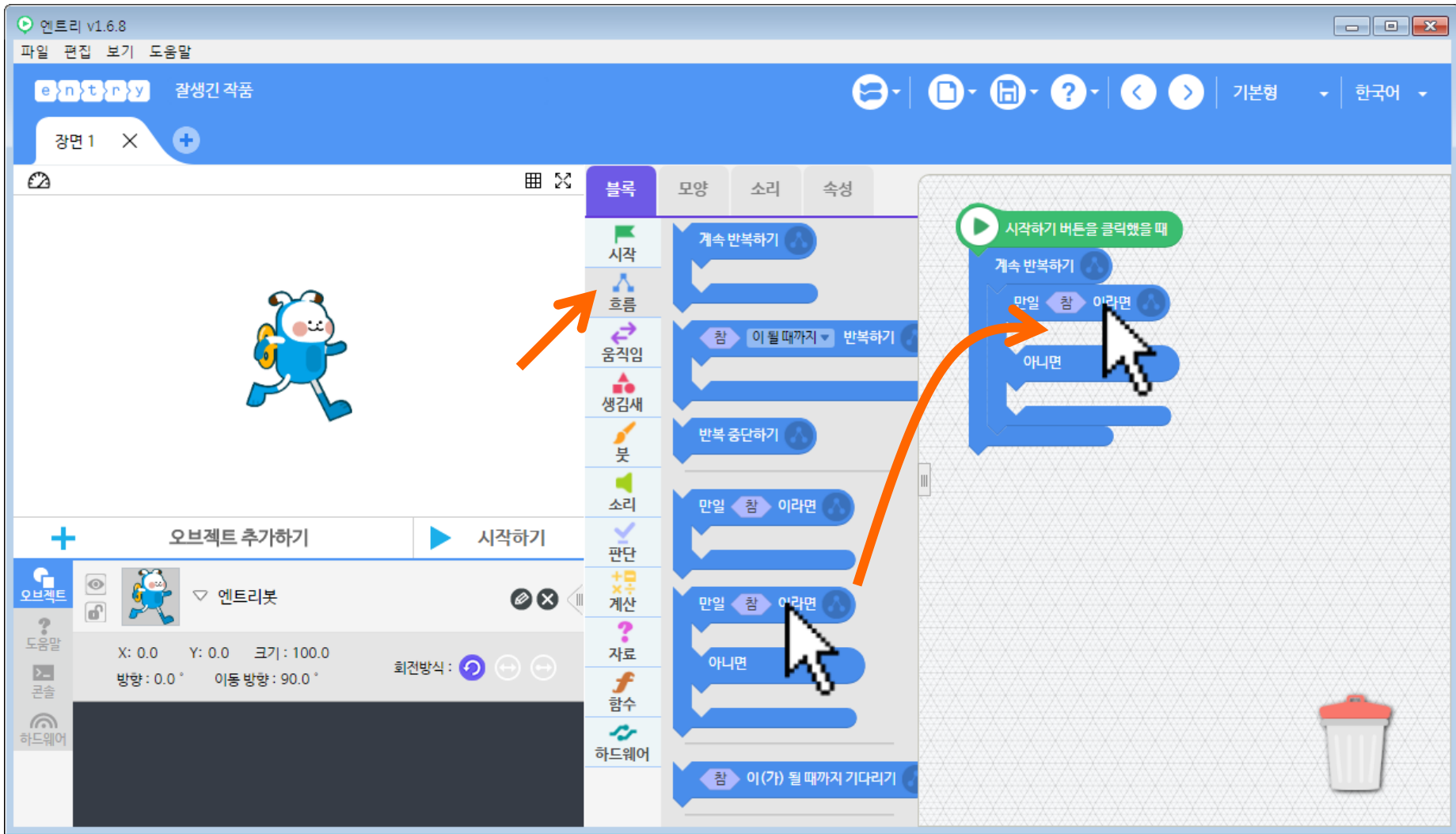

- 판단 탭 클릭

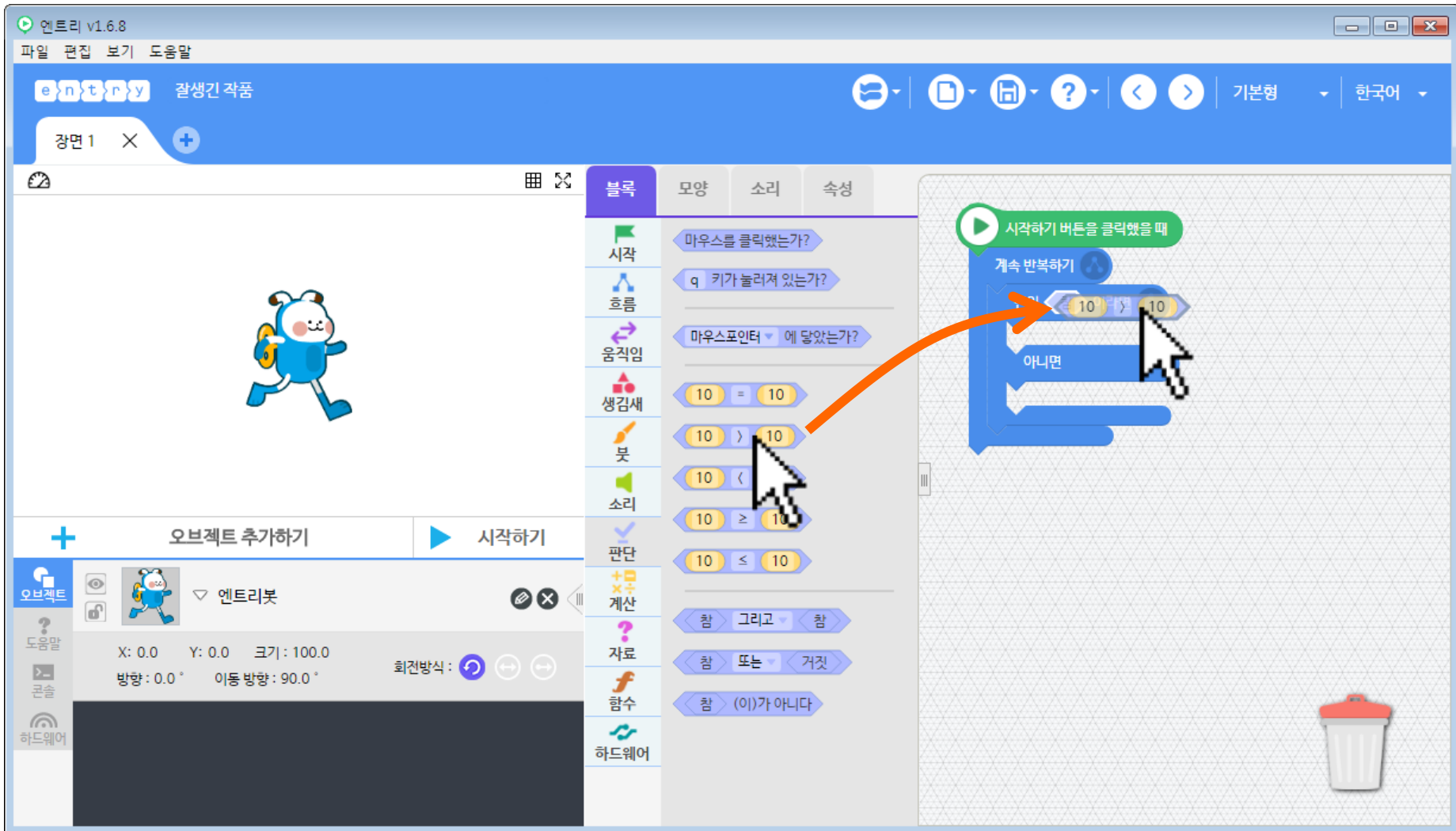

- 하드웨어 탭 클릭

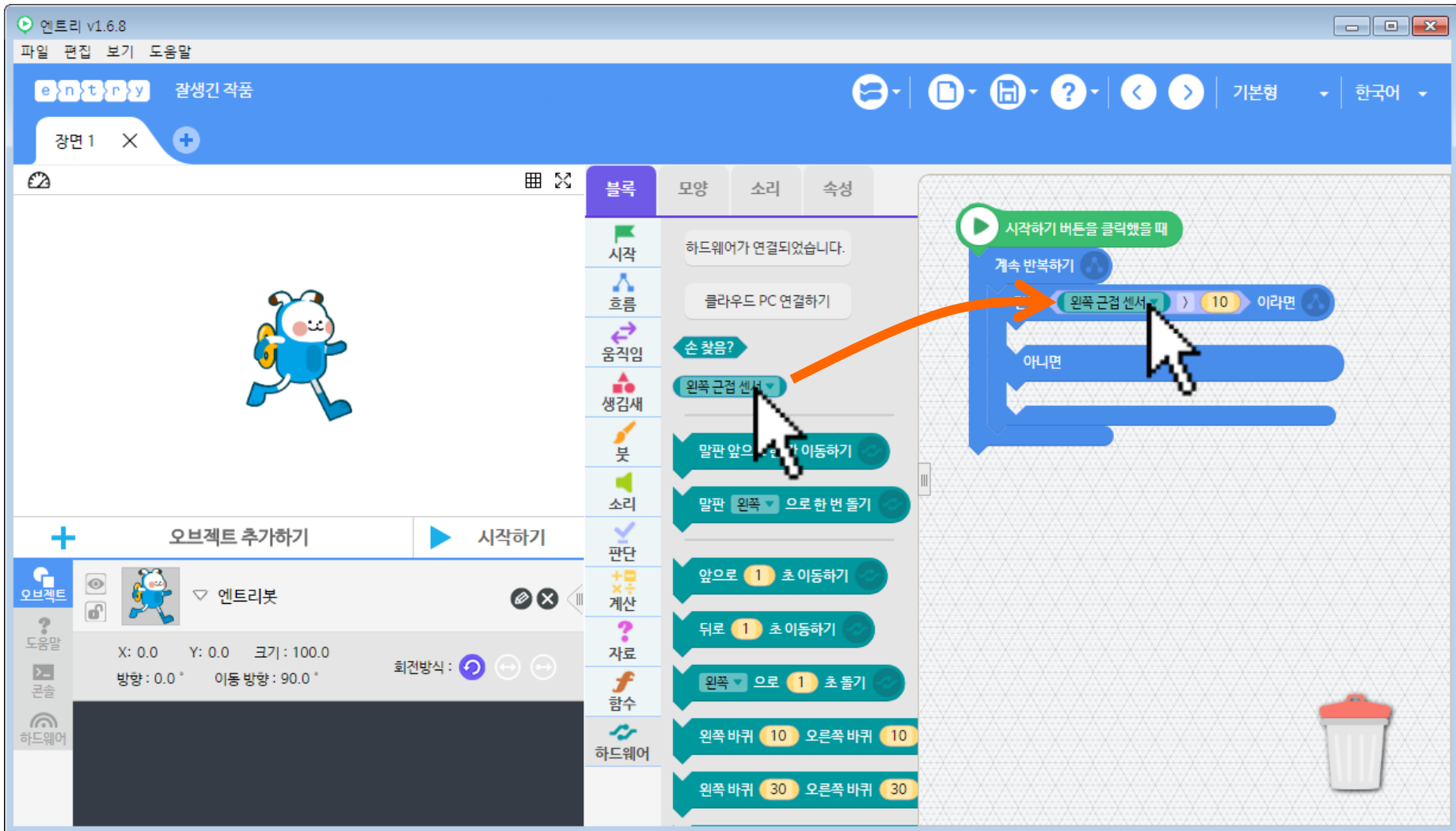

The image shows a programming environment interface with several key components:

- Stage:** A blue stage with a white background, featuring a cartoon robot character.
- Block Palette:** A vertical menu on the right with categories: 블록 (Blocks), 모양 (Looks), 소리 (Sounds), and 속성 (Properties). The '블록' category is expanded, showing various event, control, and motion blocks.
- Script Area:** A workspace on the right containing a sequence of blocks: a '시작하기 버튼을 클릭했을 때' (When clicked) block, a '10 번 반복하기' (Repeat 10 times) block, and an '이동 방향으로 10 만큼 움직이기' (Move 10 units in direction) block.
- Sensor Data Panel:** A dark grey panel on the left displaying various sensor values: 온도 19, 입력 A 48, 입력 B 45, x축 가속도 -1, y축 가속도 -38, z축 가속도 -17,8, 비저 0, 음표 0, 출력 A 0, 출력 B 0, 오른쪽 바퀴 0, 오른쪽 근접 센서 37, 왼쪽 바퀴 0, 왼쪽 근접 센서 44, 오른쪽 바닥 센서 100, 왼쪽 바닥 센서 96, 오른쪽 LED 0, 왼쪽 LED 0, and 습기 35. An orange arrow points to a Wi-Fi icon in the top-left corner of this panel.

- 손을 가까이 하거나 멀리 하면서
왼쪽 근접 센서 값의 변화를 관찰합니다.

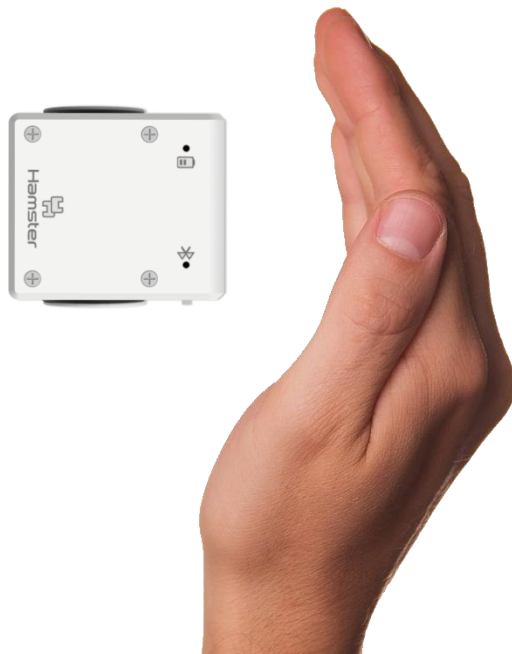



미션: 햄스터 탈출을 막아라!

37

- 햄스터 로봇이 앞으로 이동
- 앞에 장애물이 감지되면
뒤로 몇 초 이동하고
왼쪽 또는 오른쪽으로 몇 초 회전하여
다른 방향으로 앞으로 이동



바닥 센서 사용하기

왼쪽 바닥 센서
(적외선 센서)
0~100단계 감지

오른쪽 바닥 센서
(적외선 센서)
0~100단계 감지





시작하기 버튼을 클릭했을 때

왼쪽 바닥 센서 ▼



20

이 될 때까지 ▼

반복하기



왼쪽 바퀴

30

오른쪽 바퀴

30

(으)로 정하기



정지하기





키보드 사용하기



▶ 시작하기 버튼을 클릭했을 때

계속 반복하기



왼쪽 바퀴

0

오른쪽 바퀴

30

(으)로 정하기



스페이스 ▼

키가 눌러져 있는가?

이(가) 될 때까지 기다리기



왼쪽 바퀴

30

오른쪽 바퀴

0

(으)로 정하기



스페이스 ▼

키가 눌러져 있는가?

이(가) 될 때까지 기다리기



▶ 시작하기 버튼을 클릭했을 때

계속 반복하기

왼쪽 바퀴 0 오른쪽 바퀴 30 (으)로 정하기

스페이스 ▼ 키가 눌러져 있는가? 이(가) 될 때까지 기다리기

스페이스 ▼ 키가 눌러져 있는가? (이)가 아니다 이(가) 될 때까지 기다리기

왼쪽 바퀴 30 오른쪽 바퀴 0 (으)로 정하기

스페이스 ▼ 키가 눌러져 있는가? 이(가) 될 때까지 기다리기

스페이스 ▼ 키가 눌러져 있는가? (이)가 아니다 이(가) 될 때까지 기다리기

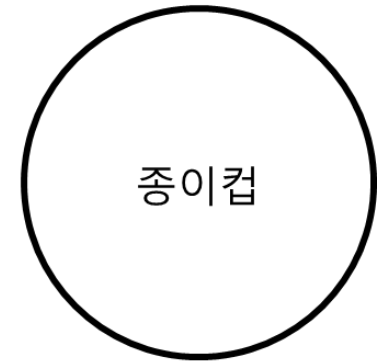
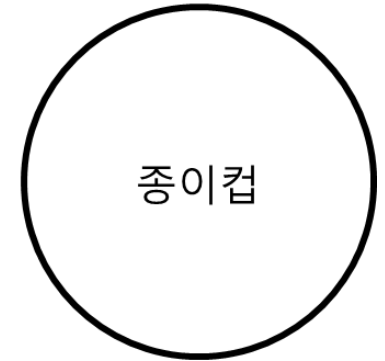

라인 트레이싱

왼쪽 센서 + 오른쪽 가장자리



▶ 시작하기 버튼을 클릭했을 때

계속 반복하기

만일 < 왼쪽 바닥 센서 > > 50 > 이라면

왼쪽 바퀴 0 오른쪽 바퀴 30 (으)로 정하기

아니면

왼쪽 바퀴 30 오른쪽 바퀴 0 (으)로 정하기

왼쪽 센서 + 오른쪽 가장자리

50

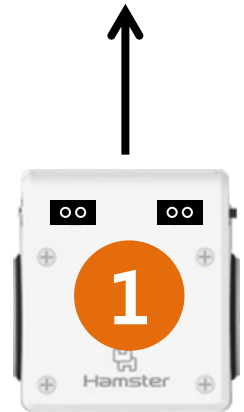
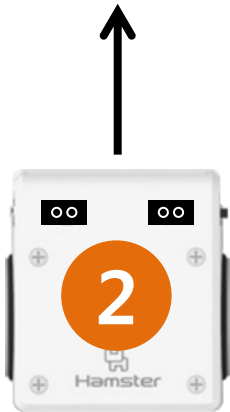

왼쪽 센서 + 오른쪽 가장자리

51

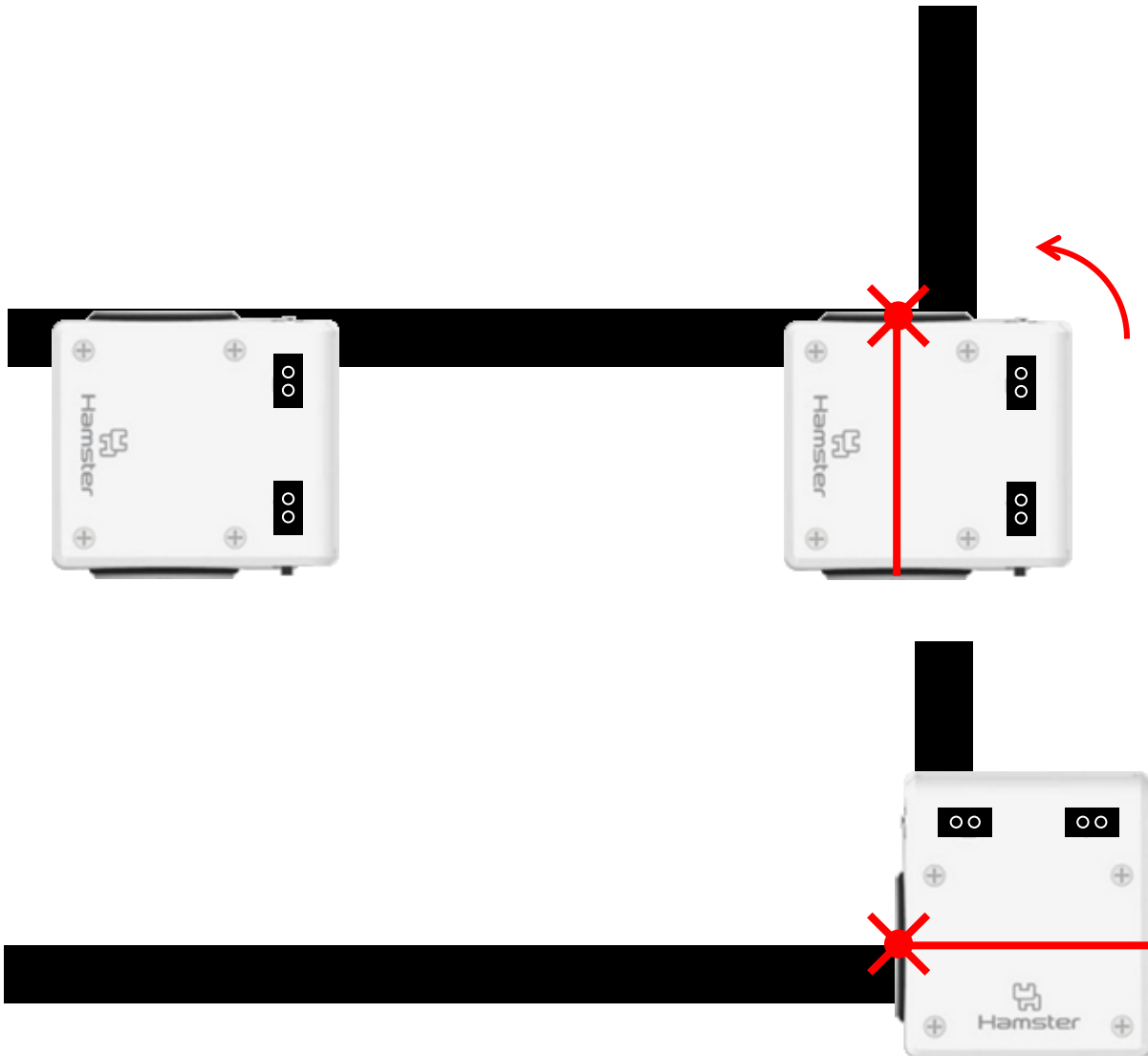

왼쪽 센서 + 오른쪽 가장자리

52

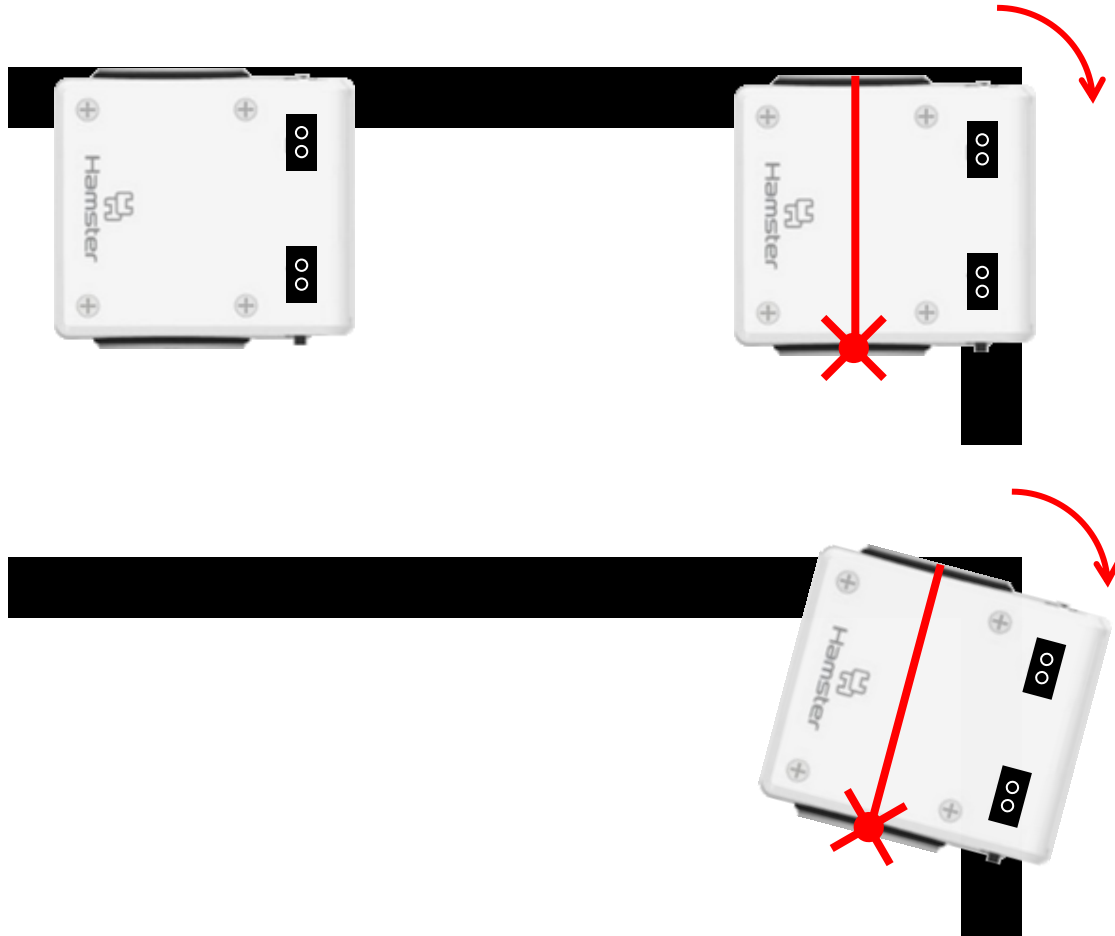

왼쪽 센서 + 오른쪽 가장자리

53

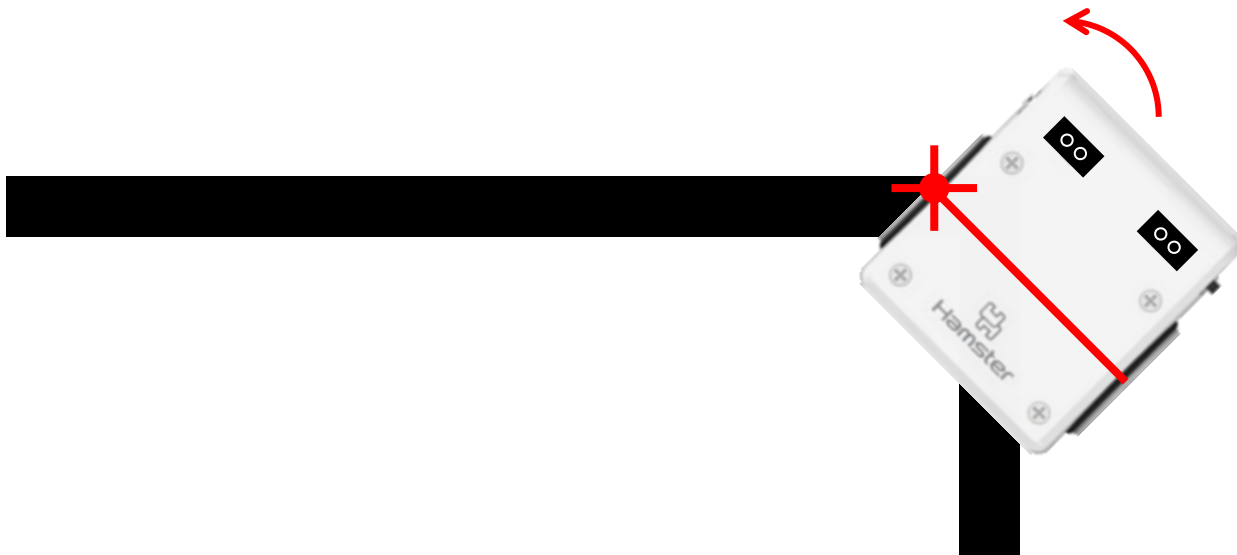

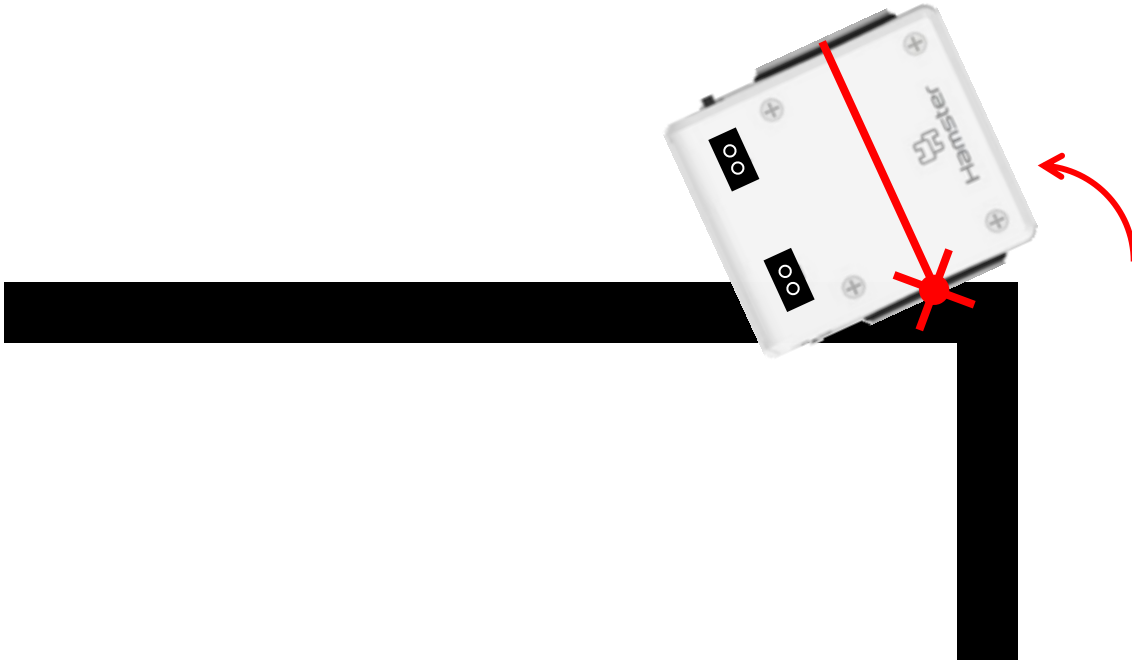

왼쪽 센서 + 왼쪽 가장자리

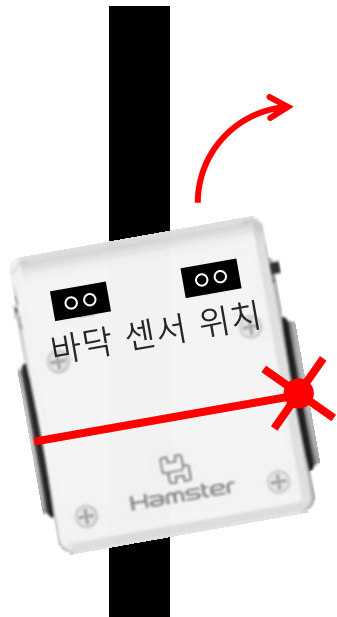

▶ 시작하기 버튼을 클릭했을 때

계속 반복하기

만일 < 왼쪽 바닥 센서 > > 50 > 이라면

왼쪽 바퀴 30 오른쪽 바퀴 0 (으)로 정하기

아니면

왼쪽 바퀴 0 오른쪽 바퀴 30 (으)로 정하기

왼쪽 센서 + 왼쪽 가장자리

57



왼쪽 센서 + 왼쪽 가장자리

58

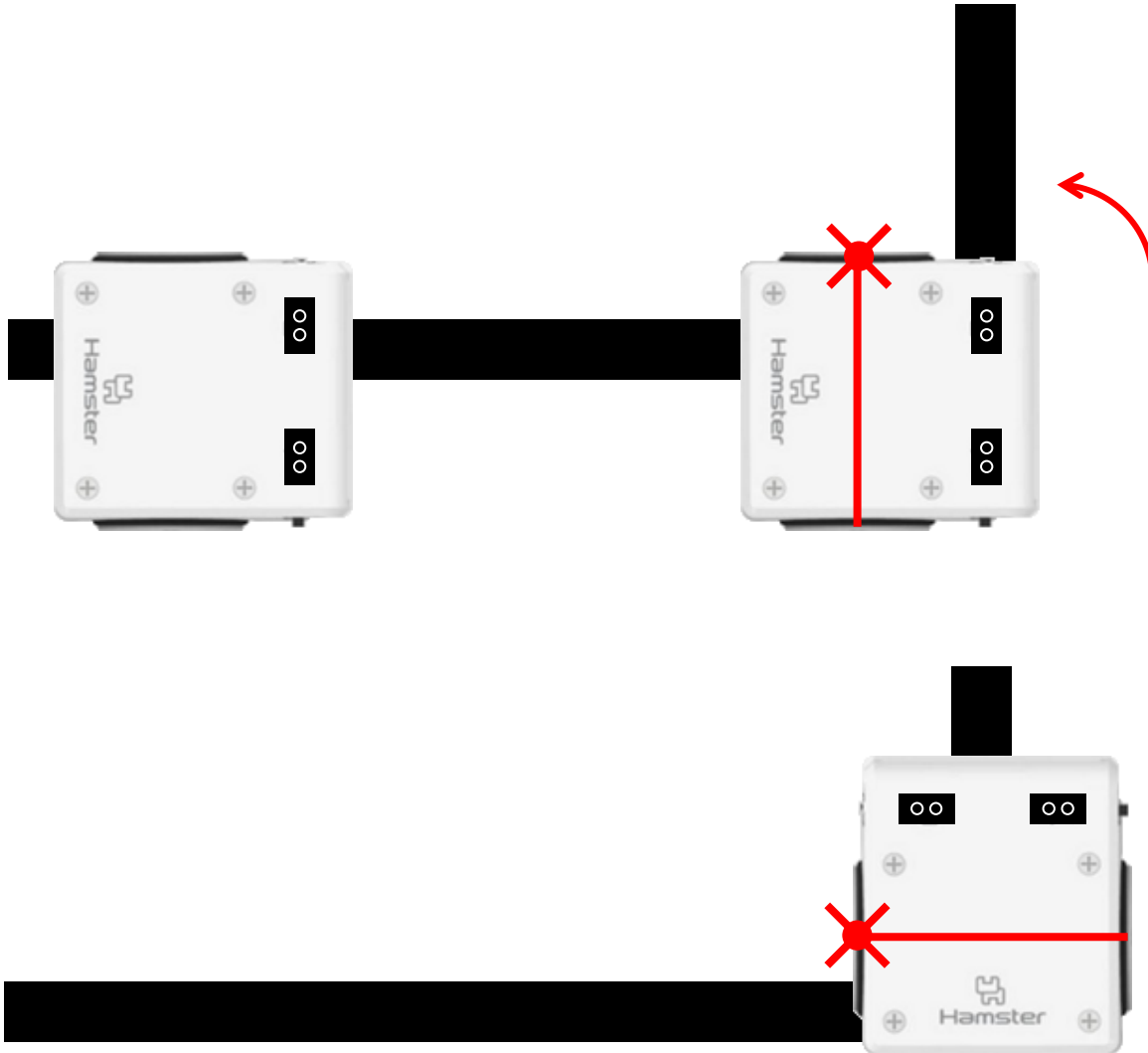

왼쪽 센서 + 왼쪽 가장자리

59

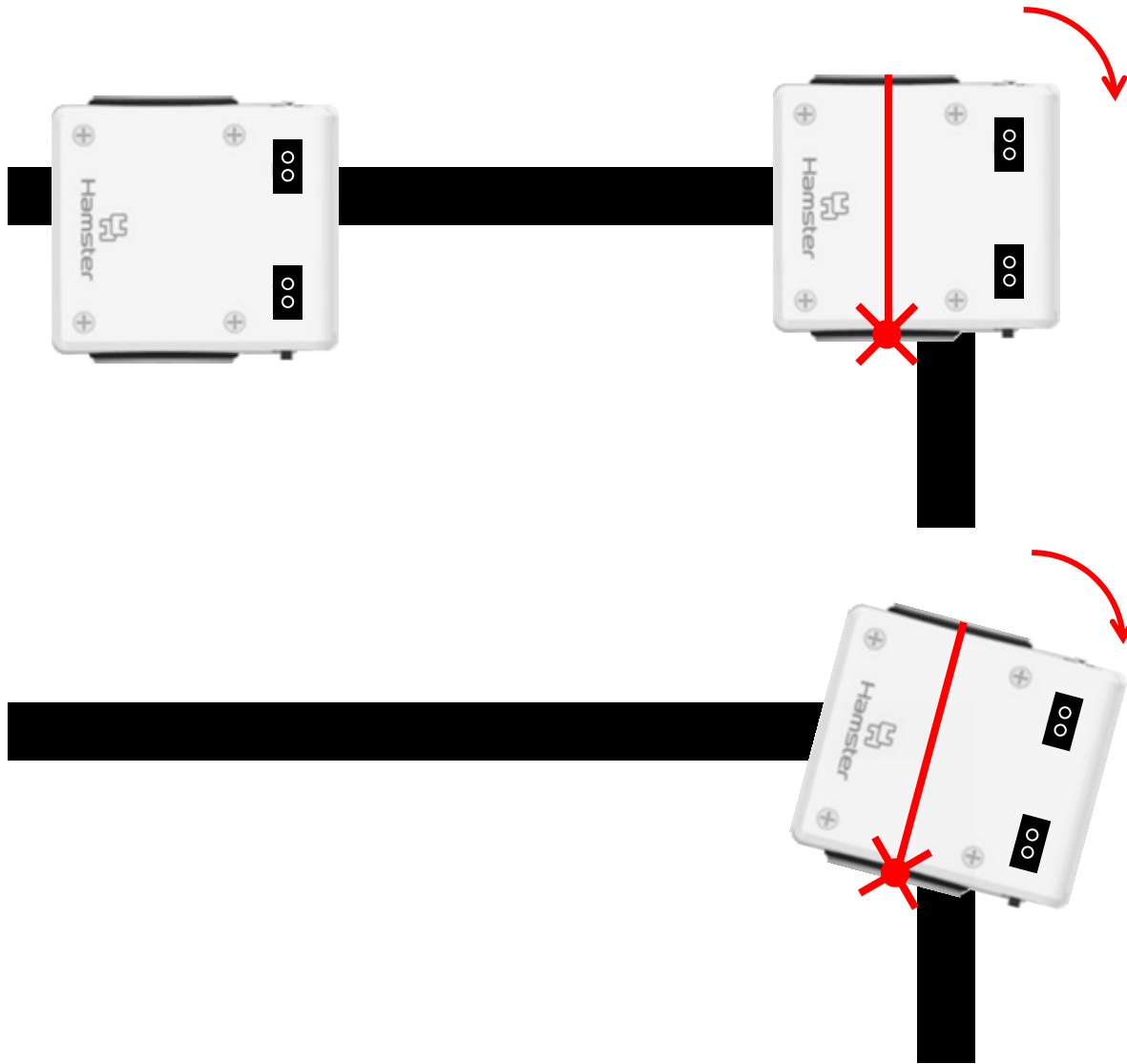



오른쪽 가장자리

왼쪽 가장자리

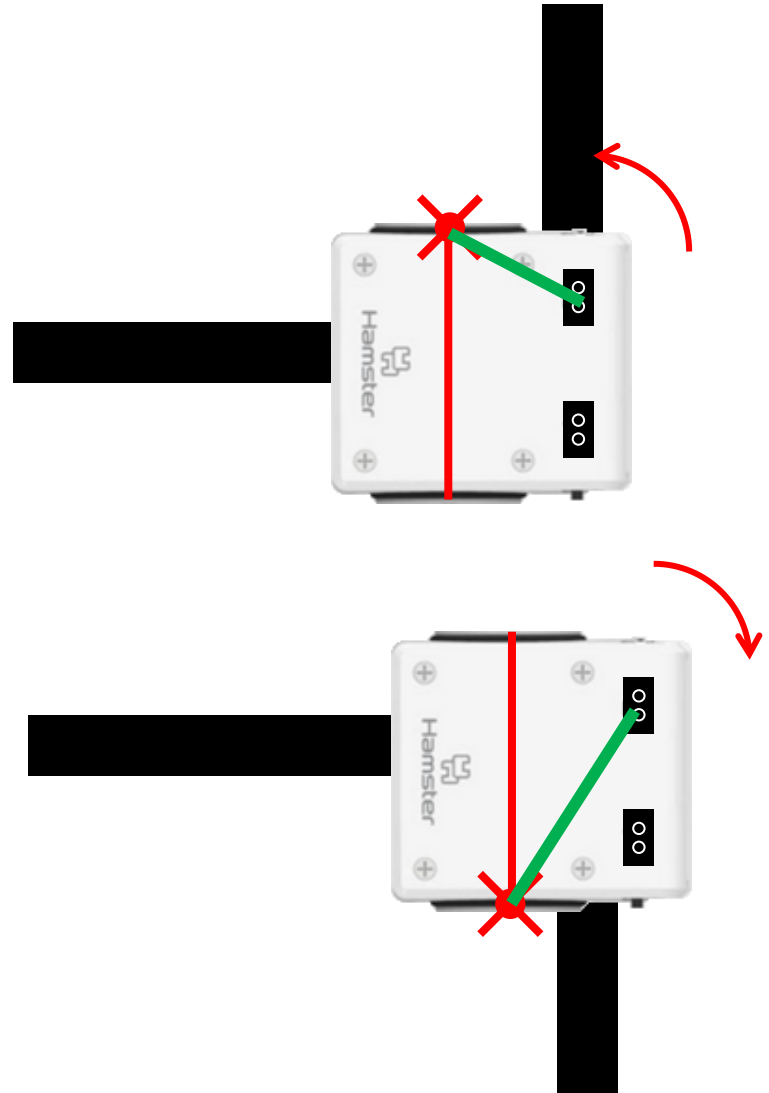
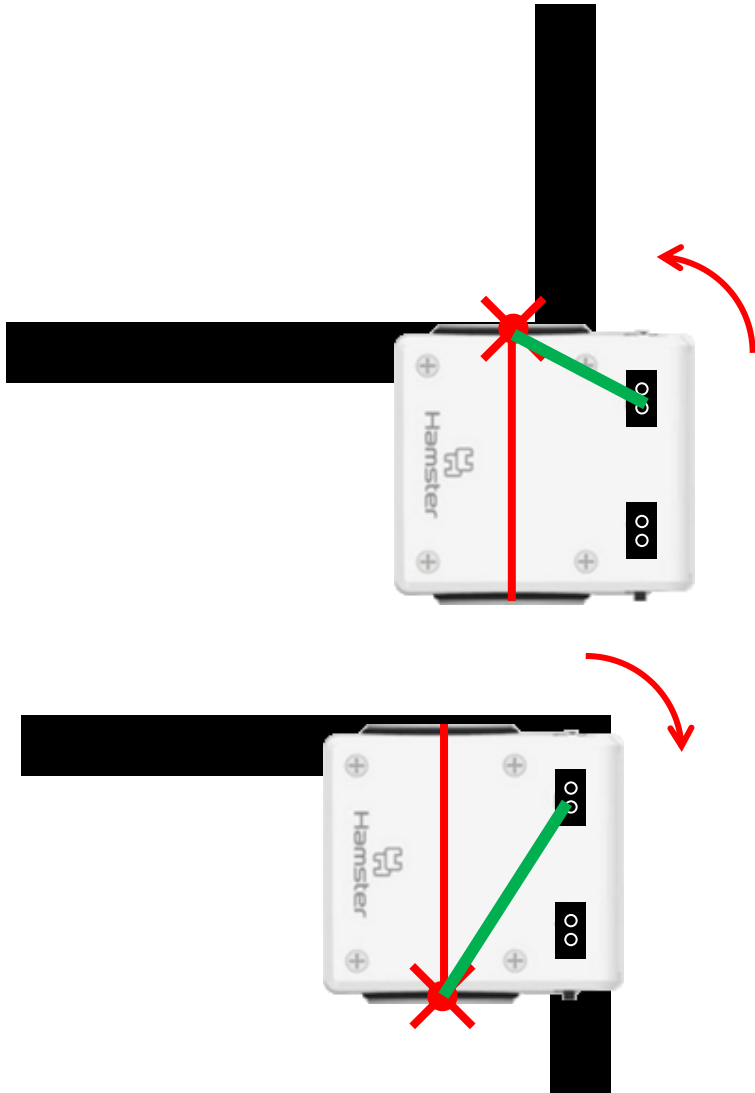

컵 따라 돌기

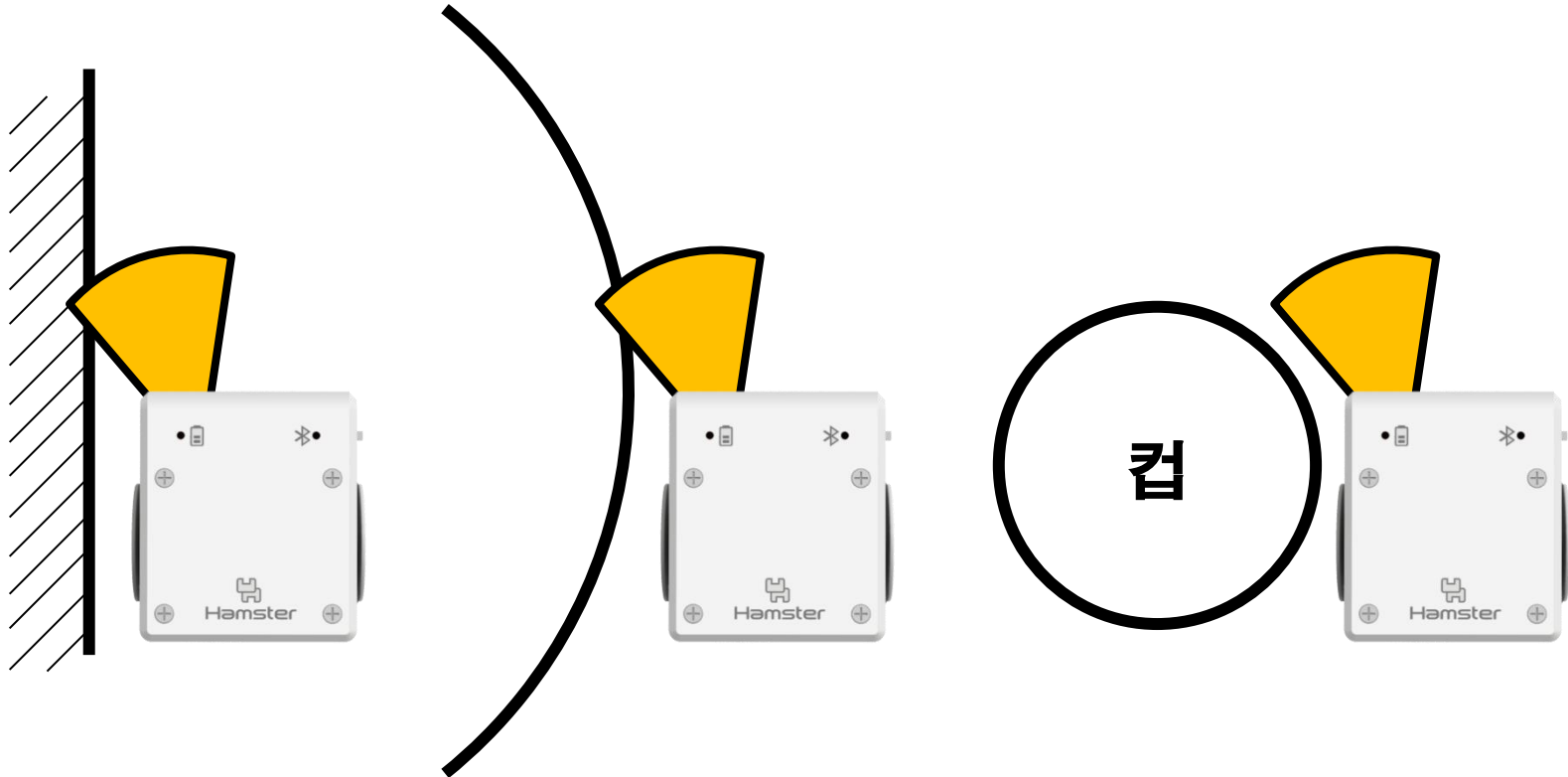

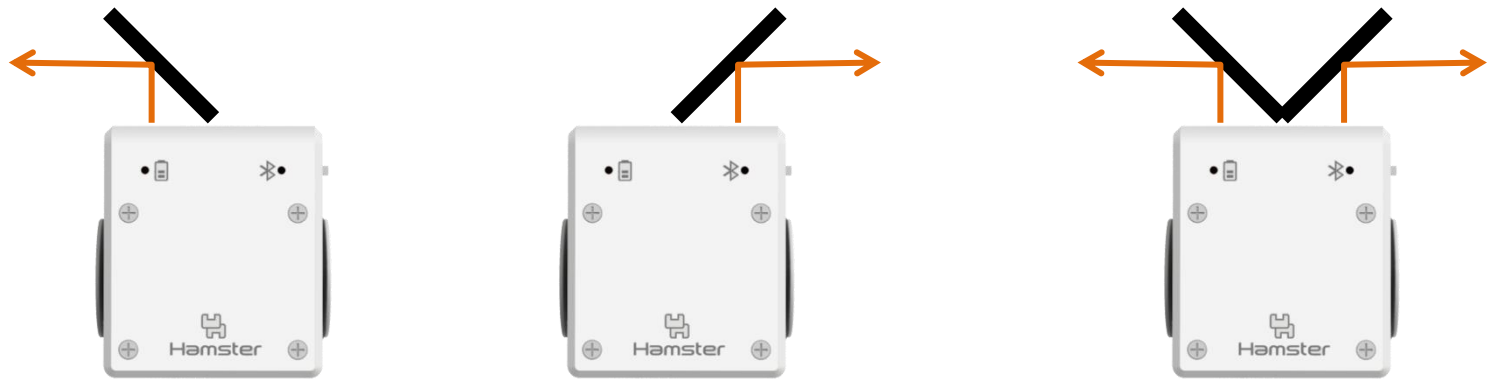

양쪽 반사판을 끼워 주세요 !!

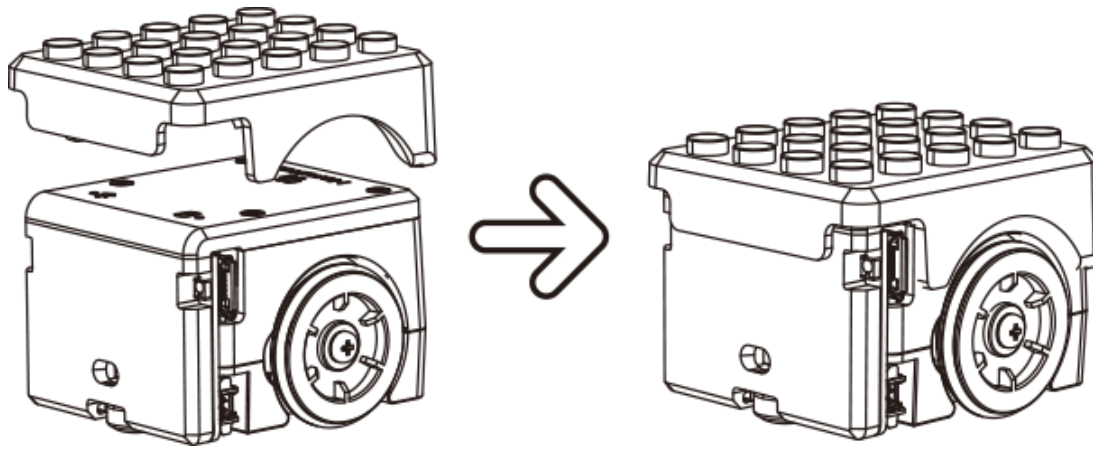

위에서 누르면 끼울 수 있어요

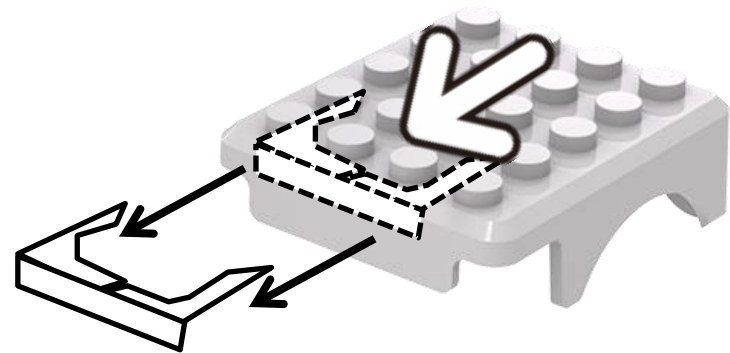
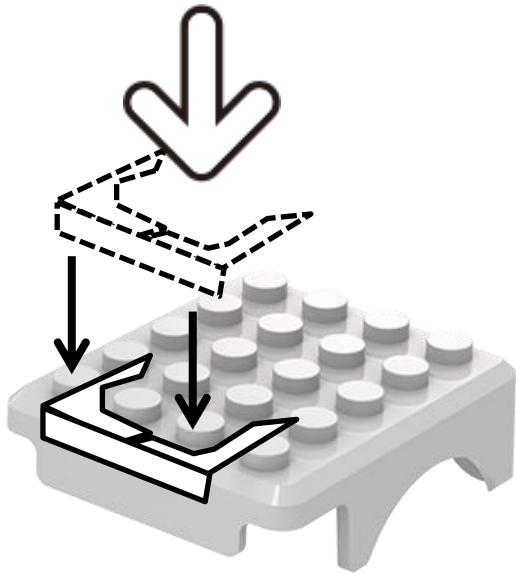

뒤에서 앞으로 밀면 뺄 수 있어요

컵 따라 돌기

67

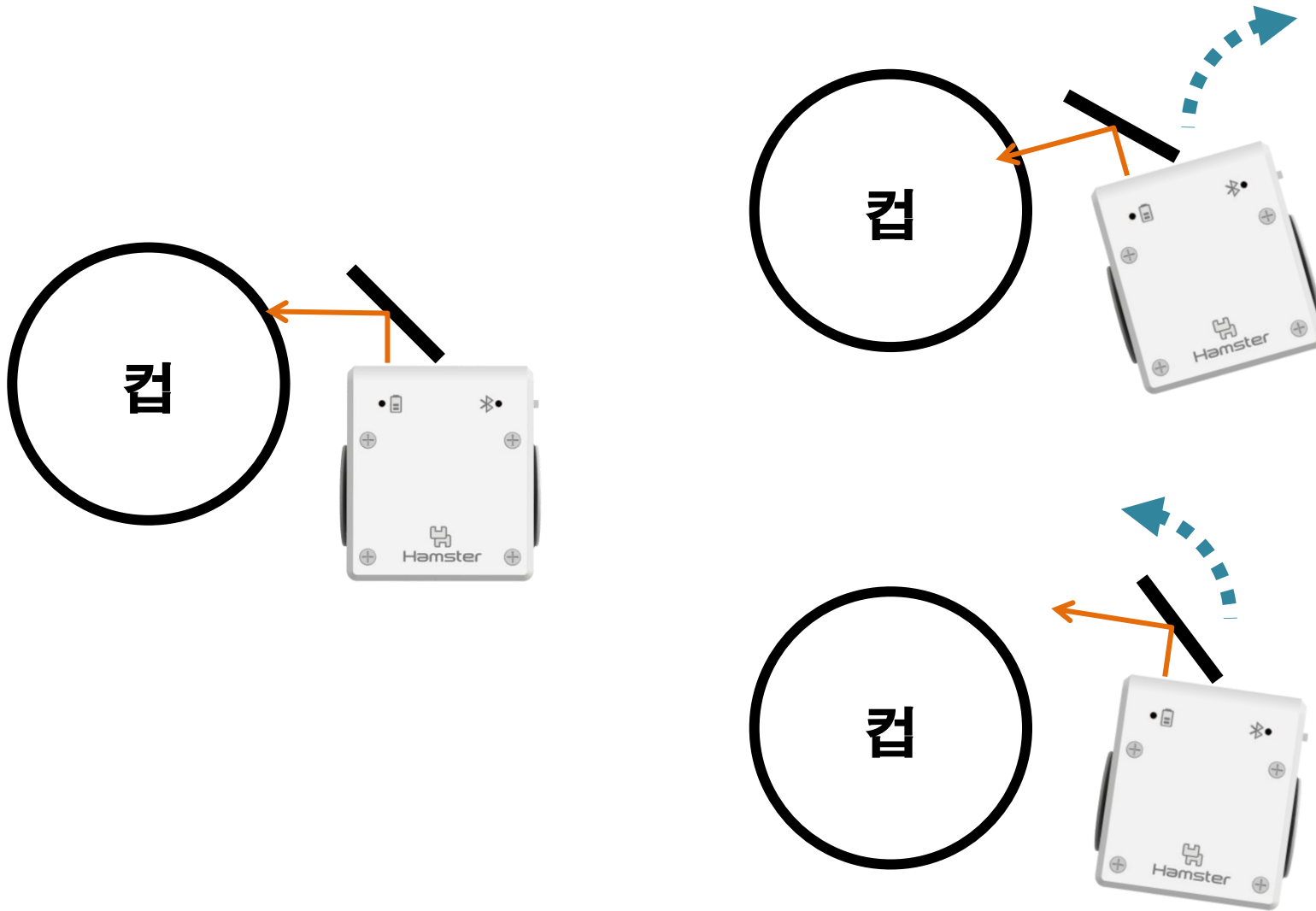

▶ 시작하기 버튼을 클릭했을 때

계속 반복하기 

만일 < 왼쪽 근접 센서 > > 10 > 이라면 

왼쪽 바퀴 30 오른쪽 바퀴 0 (으)로 정하기 

아니면

왼쪽 바퀴 0 오른쪽 바퀴 30 (으)로 정하기 

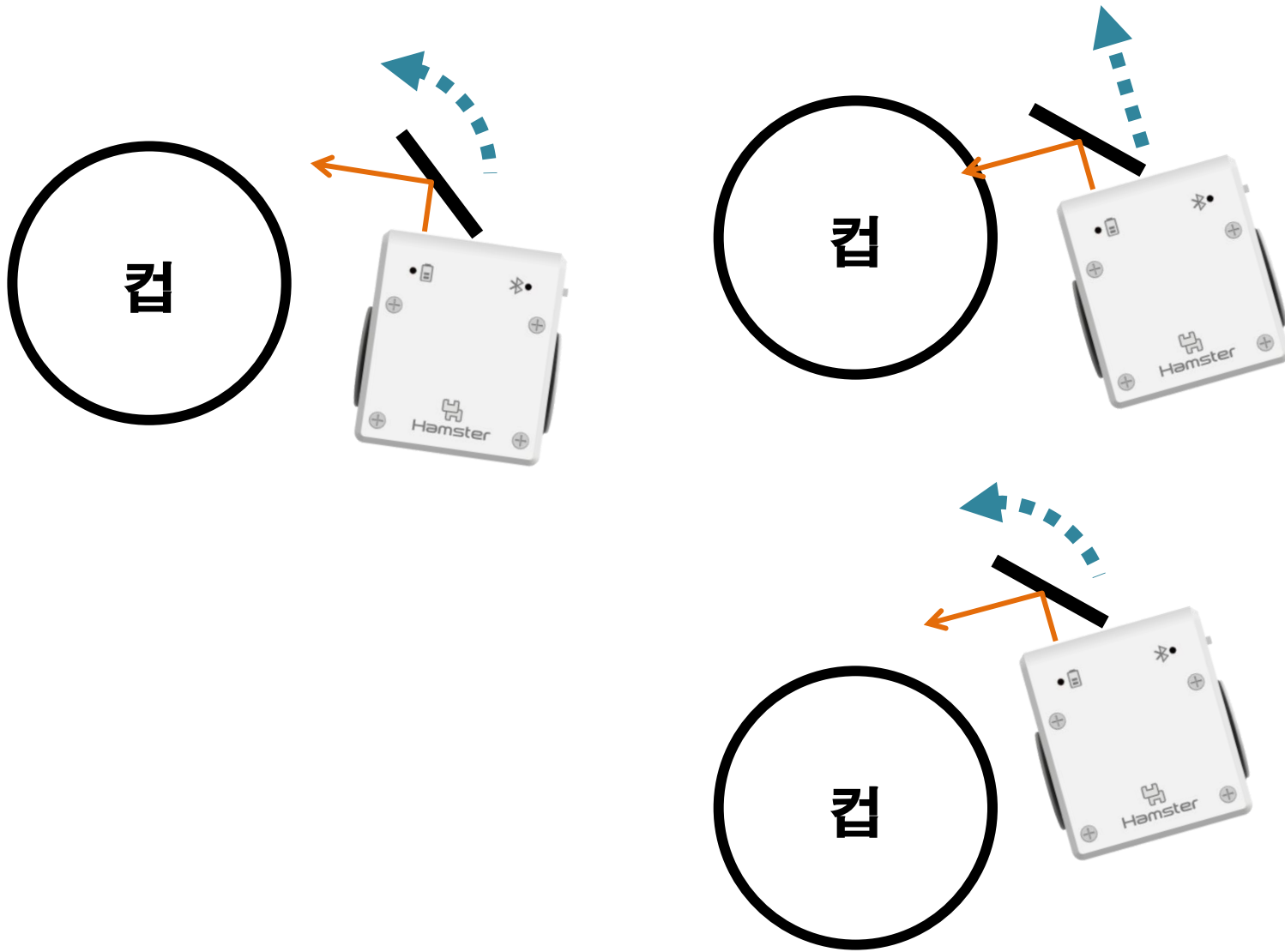

개선된 컵 따라 돌기

70

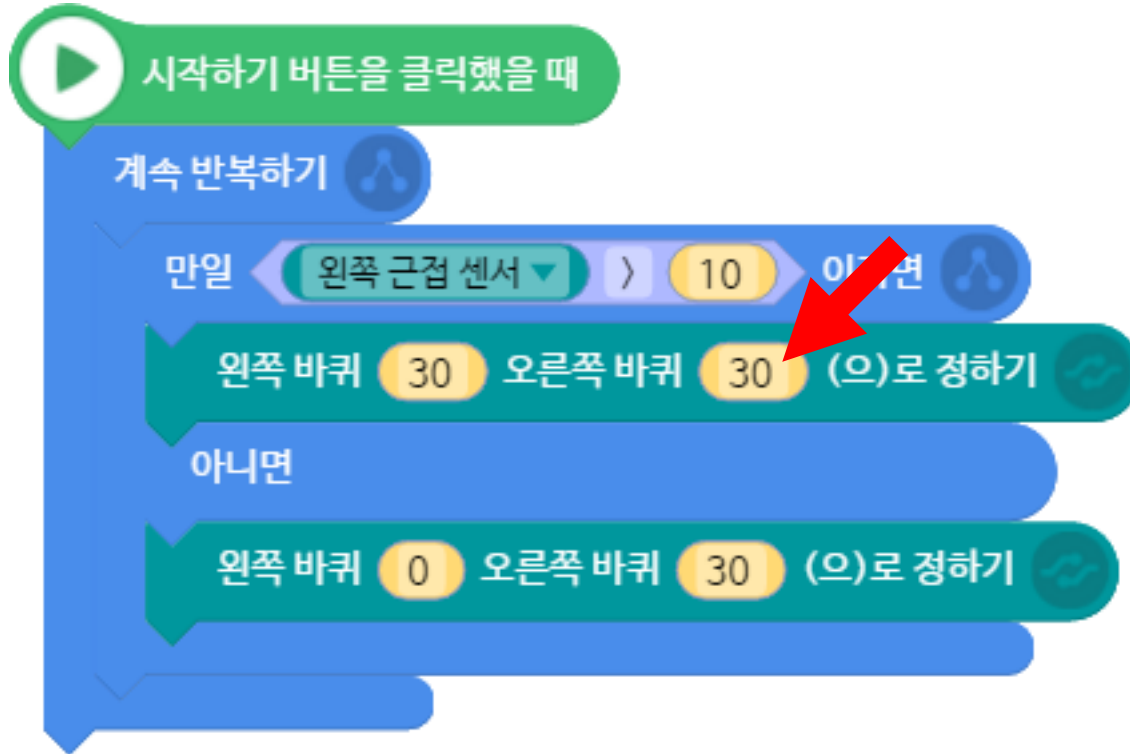

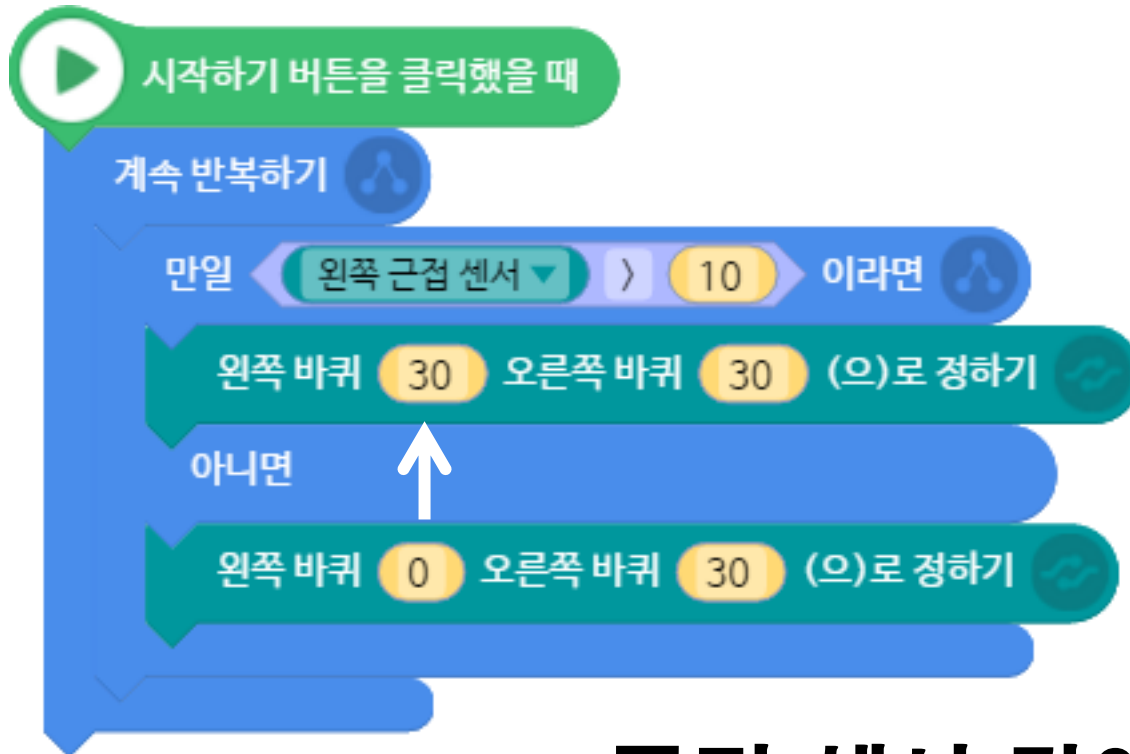

**근접 센서 값이 커지면
바퀴의 속도도 커진다 ?**

좀 더 개선된 컵 따라 돌기

72



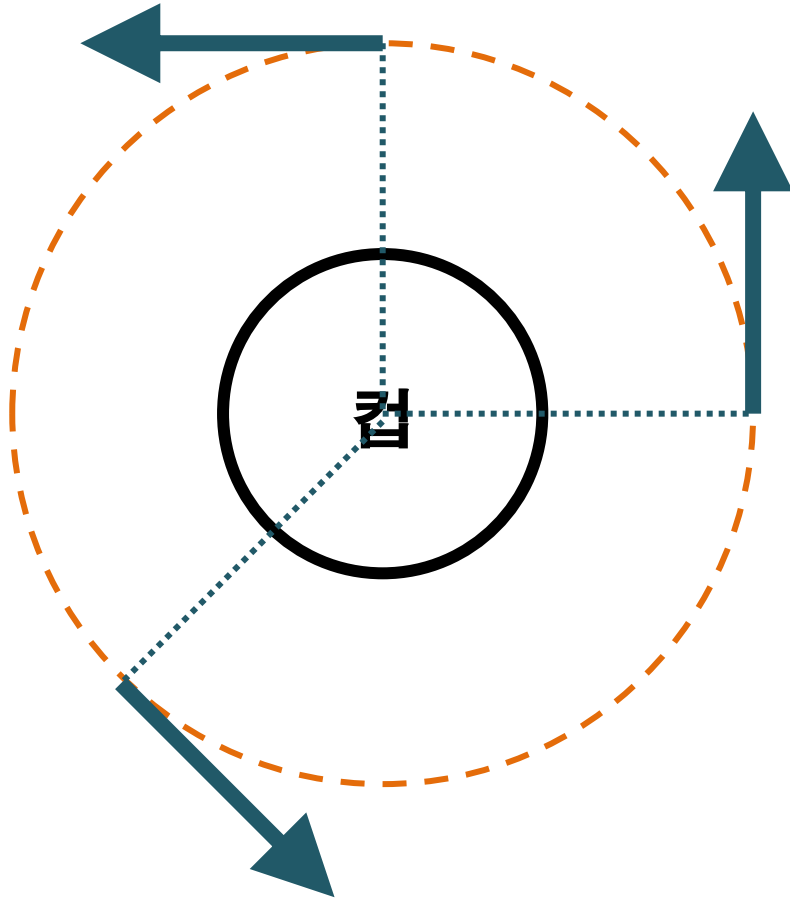

원하는 거리만큼 떨어져서 돌기

센서 위치를 컵의 중심에
맞춘다 !!

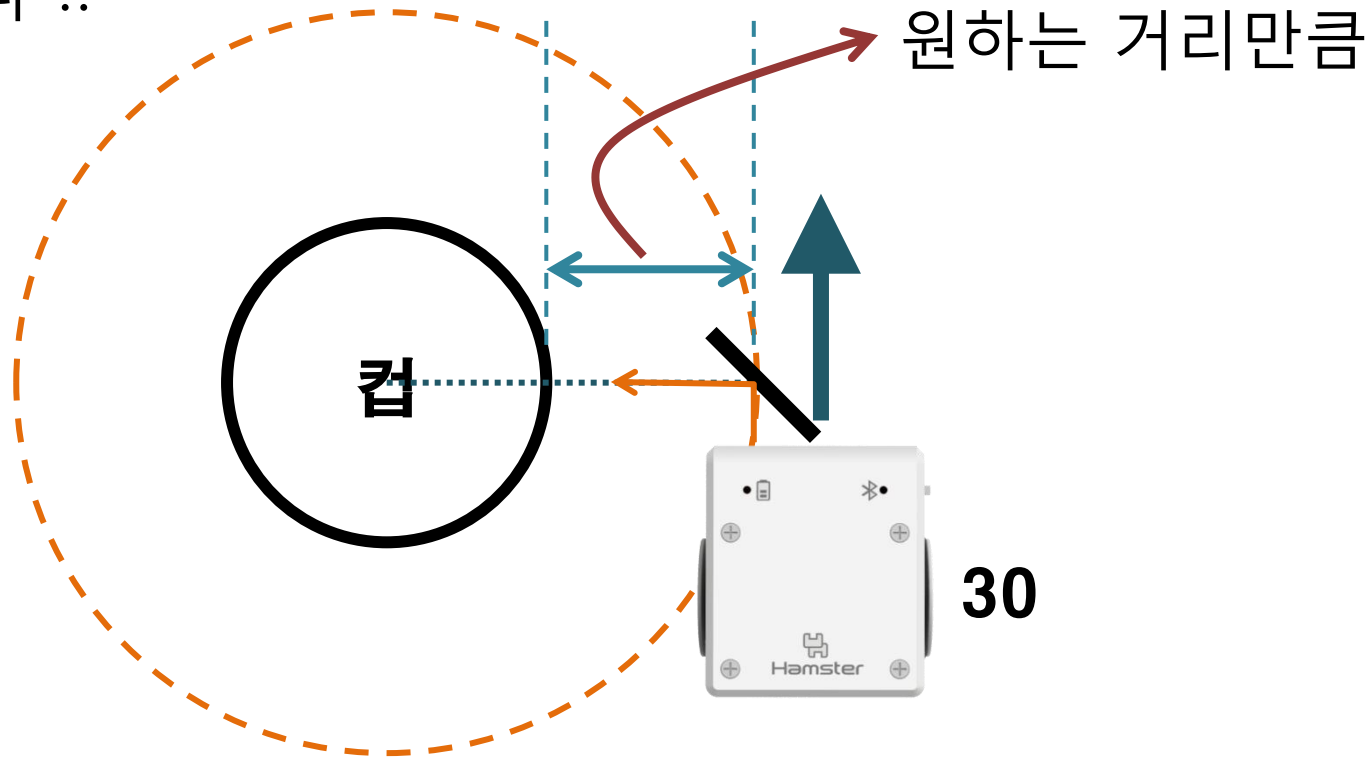

원하는 거리만큼 떨어져서 돌기

75

센서 위치를 컵의 중심에
맞춘다 !!

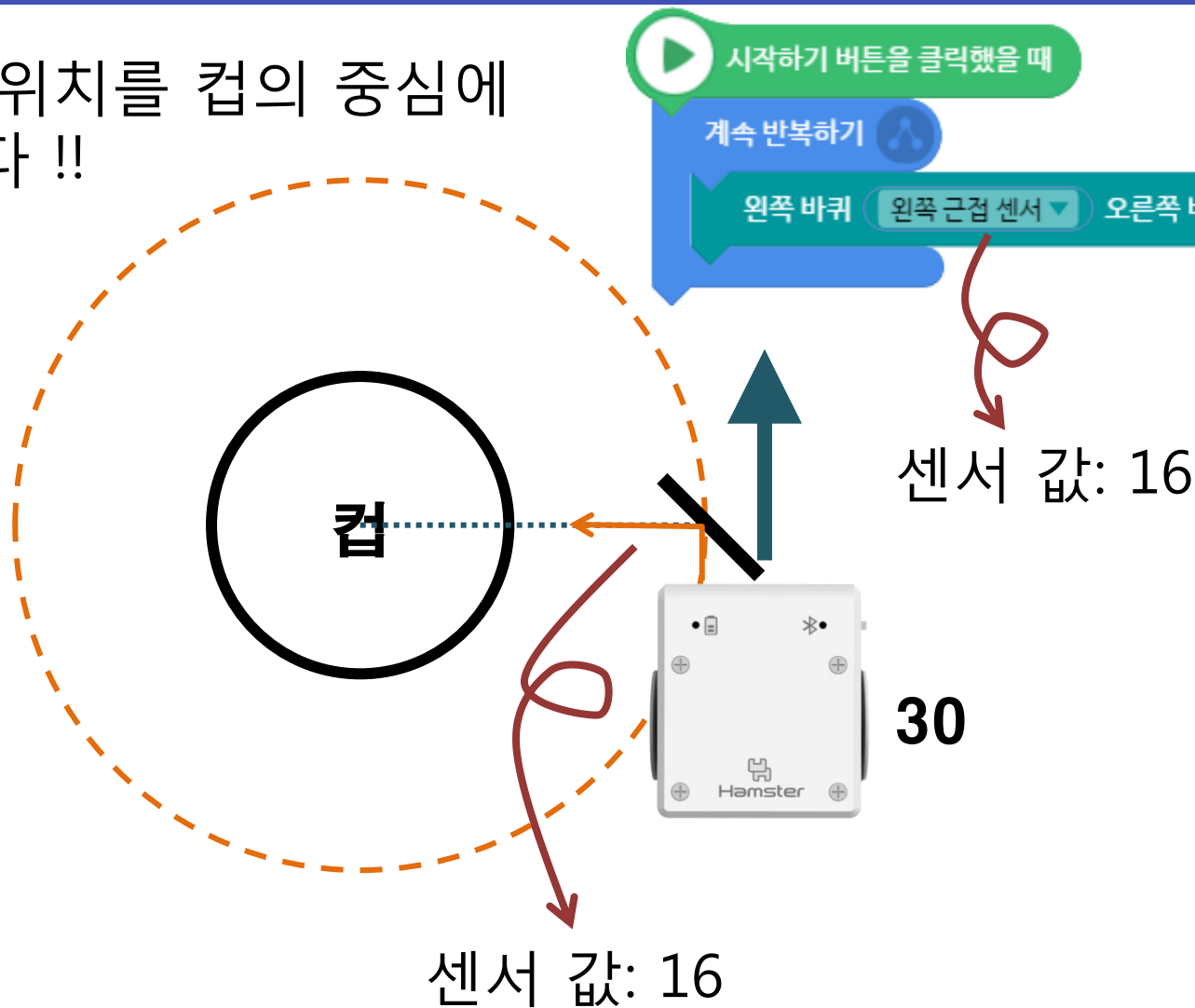

원하는 거리만큼 떨어져서 돌기

76

센서 위치를 컵의 중심에
맞춘다 !!

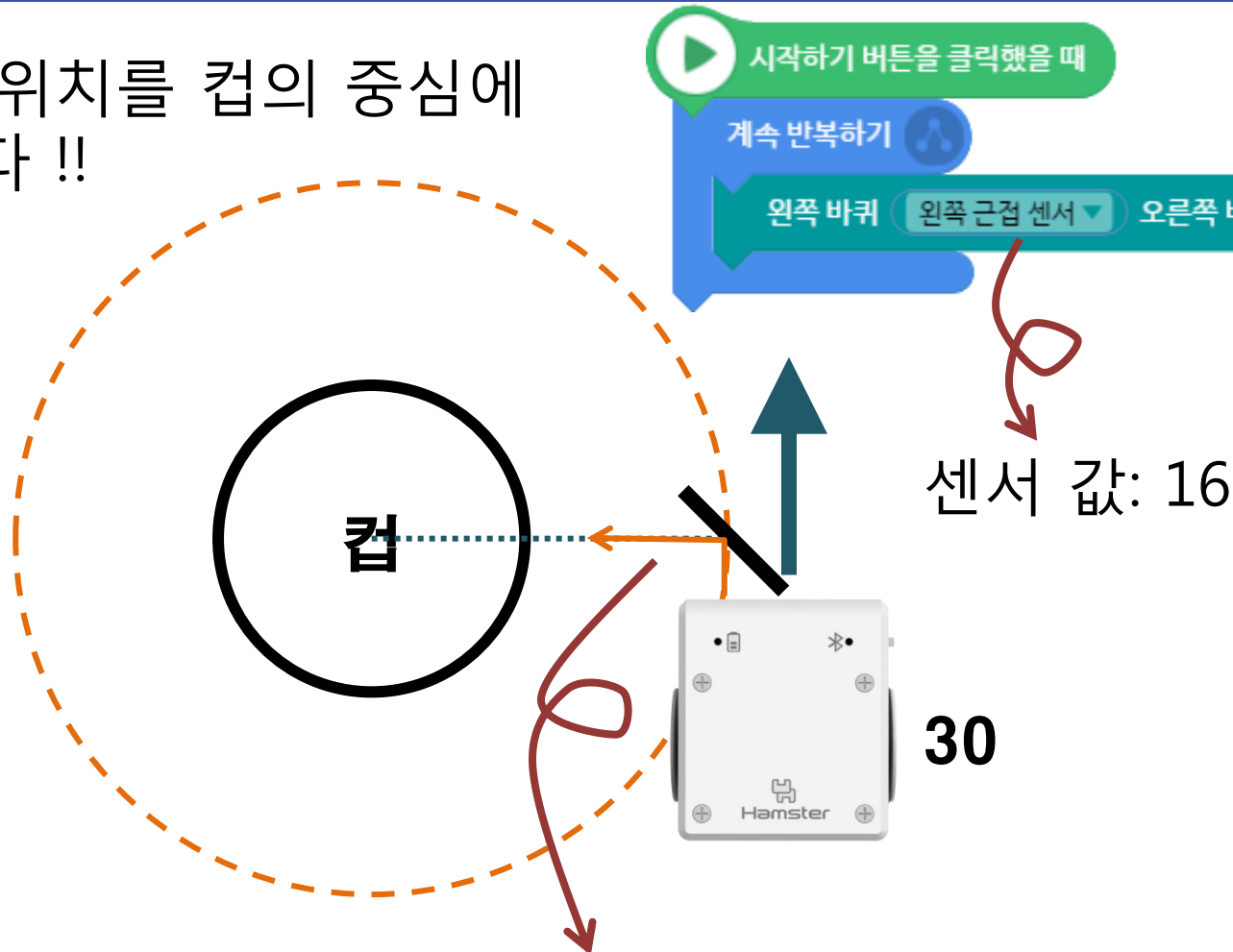

센서 값: 16

$$30 \div 16 = 1.875$$

원하는 거리만큼 떨어져서 돌기

77

시작하기 버튼을 클릭했을 때

계속 반복하기

왼쪽 바퀴 x 오른쪽 바퀴 (으)로 정하기



수고하셨습니다.

<http://hamster.school>

akaii@kw.ac.kr